

PROSPECTUS SUPPLEMENT
(To Prospectus dated December 1, 2014)



1,935,500 Shares of Common Stock

We are offering 1,935,500 shares of our common stock. Our common stock is quoted on The NASDAQ Capital Market under the symbol "IPWR." On May 12, 2015, the last reported sale price of our common stock was \$9.04 per share.

We are an "emerging growth company" as that term is used in the Jumpstart Our Business Startups Act of 2012 and, as such, have elected to comply with certain reduced public company reporting requirements for this prospectus and future filings. See "Prospectus Supplement Summary—Implications of Being an Emerging Growth Company."

An investment in our common stock involves significant risks. See "Risk Factors," beginning on page S-4 of this prospectus supplement for a discussion of the factors you should carefully consider before deciding to purchase our common stock.

Neither the Securities and Exchange Commission nor any state securities commission has approved or disapproved of these securities or determined if this prospectus supplement or the accompanying prospectus is truthful or complete. Any representation to the contrary is a criminal offense.

As of April 29, 2015, the aggregate market value of the voting and non-voting common equity held by non-affiliates, computed by reference to the price at which the common equity was last sold on that date, was approximately \$52,950,090, based on 7,084,953 shares of our outstanding common stock, of which 4,715,057 were held by non-affiliates. Pursuant to General Instruction I.B.6 of Form S-3, in no event will we sell securities in a public primary offering with a value exceeding more than one-third of our public float in any 12-month period so long as our public float remains below \$75.0 million. We have not offered any securities pursuant to General Instruction I.B.6 of Form S-3 during the 12 calendar months prior to and including the date of this prospectus.

	<i>Per Share</i>	<i>Total</i>
Public offering price	\$ 7.750	\$ 15,000,125
Underwriting discount ⁽¹⁾	\$ 0.465	\$ 900,008
Proceeds, before expenses, to us	\$ 7.285	\$ 14,100,118

(1) We have agreed to reimburse the underwriters for certain expenses incurred by them in connection with this offering. See "Underwriting" beginning on page S-27 of this prospectus supplement for a description of the compensation payable to the underwriters.

The underwriters may also purchase additional shares from us at the public offering price, less the underwriting discount, within 30 days from the date of this prospectus supplement to cover over-allotments.

The underwriters expect to deliver the shares against payment through the facilities of the Depository Trust Company on May 20, 2015.

Sole Book-Running Manager

Roth Capital Partners

Co-Managers

National Securities Corporation

Northland Capital Markets

The date of this prospectus supplement is May 18, 2015.

TABLE OF CONTENTS

	Page
Prospectus Supplement	
ABOUT THIS PROSPECTUS SUPPLEMENT	S-ii
CAUTIONARY NOTE REGARDING FORWARD-LOOKING STATEMENTS	S-iii
PROSPECTUS SUPPLEMENT SUMMARY	S-1
THE OFFERING	S-3
RISK FACTORS	S-4
USE OF PROCEEDS	S-14
PRICE RANGE OF OUR COMMON STOCK	S-15
DIVIDEND POLICY	S-15
CAPITALIZATION	S-16
DILUTION	S-17
OUR BUSINESS	S-18
UNDERWRITING	S-27
LEGAL MATTERS	S-30
EXPERTS	S-30
WHERE YOU CAN FIND ADDITIONAL INFORMATION	S-30
INCORPORATION OF CERTAIN INFORMATION BY REFERENCE	S-30
Prospectus	
ABOUT THIS PROSPECTUS	2
OUR BUSINESS	2
RISK FACTORS	4
DISCLOSURE REGARDING FORWARD-LOOKING STATEMENTS	4
USE OF PROCEEDS	4
THE SECURITIES WE MAY OFFER	4
DESCRIPTION OF CAPITAL STOCK	5
DESCRIPTION OF WARRANTS	7
PLAN OF DISTRIBUTION	9
LEGAL MATTERS	12
EXPERTS	12
WHERE YOU CAN FIND MORE INFORMATION	12
INCORPORATION OF DOCUMENTS BY REFERENCE	13

ABOUT THIS PROSPECTUS SUPPLEMENT

This document is in two parts. The first part is the prospectus supplement, which describes the specific terms of this offering and also adds to and updates information contained in the accompanying prospectus and the documents incorporated by reference into this prospectus supplement and the accompanying prospectus. The second part, the accompanying prospectus, provides more general information about securities we may offer from time to time, some of which does not apply to this offering. Generally, when we refer to this prospectus, we are referring to both parts of this document combined together with all documents incorporated by reference. Before you invest, you should carefully read this prospectus supplement, the accompanying prospectus, all information incorporated by reference herein and therein, as well as the additional information described under “Where You Can Find Additional Information” and “Incorporation of Certain Information By Reference” on page S-30 of this prospectus supplement. These documents contain information you should consider when making your investment decision. To the extent there is a conflict between the information contained in this prospectus supplement, on the one hand, and the information contained in the accompanying prospectus or any document incorporated by reference therein filed prior to the date of this prospectus supplement, on the other hand, you should rely on the information in this prospectus supplement. If any statement in one of these documents is inconsistent with a statement in another document having a later date—for example, a document filed after the date of this prospectus supplement and incorporated by reference in this prospectus supplement and the accompanying prospectus—the statement in the document having the later date modifies or supersedes the earlier statement.

You should rely only on the information contained or incorporated by reference in this prospectus supplement, the accompanying prospectus and in any free writing prospectuses we may provide to you in connection with this offering. We have not, and the underwriters have not, authorized any other person to provide you with any information that is different. If anyone provides you with different or inconsistent information, you should not rely on it.

We further note that the representations, warranties and covenants made by us in any agreement that is filed as an exhibit to any document that is incorporated by reference in the accompanying prospectus were made solely for the benefit of the parties to such agreement, including, in some cases, for the purpose of allocating risk among the parties to such agreements, and should not be deemed to be a representation, warranty or covenant to you. Moreover, such representations, warranties or covenants were accurate only as of the date when made. Accordingly, such representations, warranties and covenants should not be relied on as accurately representing the current state of our affairs.

We are offering to sell, and seeking offers to buy, our securities only in jurisdictions where offers and sales are permitted. The distribution of this prospectus supplement and the offering of the securities in certain jurisdictions may be restricted by law. Persons outside the United States who come into possession of this prospectus supplement must inform themselves about, and observe any restrictions relating to, the offering of the securities and the distribution of this prospectus supplement outside the United States. This prospectus supplement does not constitute, and may not be used in connection with, an offer to sell, or a solicitation of an offer to buy, any securities offered by this prospectus supplement by any person in any jurisdiction in which it is unlawful for such person to make such an offer or solicitation.

This prospectus supplement, the accompanying prospectus, and the information incorporated herein and therein by reference, include trademarks, service marks and trade names owned by us or other companies. All trademarks, service marks and trade names included or incorporated by reference into this prospectus supplement or the accompanying prospectus are the property of their respective owners.

CAUTIONARY NOTE REGARDING FORWARD-LOOKING STATEMENTS

This prospectus supplement, the accompanying prospectus and the SEC filings that are incorporated by reference into this prospectus supplement and the accompanying prospectus contain or incorporate by reference forward-looking statements within the meaning of Section 27A of the Securities Act and Section 21E of the Securities Exchange Act of 1934, as amended (the Exchange Act). All statements, other than statements of historical fact, included or incorporated by reference in this prospectus supplement or the accompanying prospectus, including but not limited to statements regarding our anticipated expenditures, including those related to general and administrative expenses, the potential size of the market for our products, future development and/or expansion of our products in our markets, our ability to generate product revenues or effectively manage our gross profit margins, our ability to continue operating as a going concern, our ability to repay or refinance some or all of our outstanding indebtedness, and our ability to raise capital in the future, and expectations as to our future performance, are forward-looking statements. The words “believe,” “anticipate,” “estimate,” “plan,” “expect,” “intend,” “may,” “could,” “should,” “potential,” “likely,” “projects,” “continue,” “will,” and “would” and similar expressions are intended to identify forward-looking statements, although not all forward-looking statements contain these identifying words. We cannot guarantee that we actually will achieve the plans, intentions or expectations expressed in our forward-looking statements and you should not place undue reliance on our forward-looking statements. There are a number of important factors that could cause our actual results to differ materially from those indicated or implied by forward-looking statements.

These forward-looking statements include, but are not limited to, statements about:

- our ability to successfully market and sell our existing products.
- the size and growth of markets for our current and future products.
- our expectations regarding the growth and expansion of our customer base.
- regulatory developments that may affect our business.
- our ability to successfully develop new technologies, including our bi-directional insulated-gate bipolar transistor, or BD-IGBT.
- our expectations regarding the completion of testing of new products under development and the timing of the introduction of those new products.
- the expected performance of new products incorporating our BD-IGBT.
- the performance of third-party manufacturers who supply and manufacture our products.
- the rate and degree of market acceptance for our current and future products.
- our ability to successfully obtain UL 1741 certification for our products and the timing of the receipt of any necessary certifications.
- our ability to successfully license our technology.
- our ability to obtain, maintain, defend and enforce intellectual property rights protecting our current and future products.
- our expectations regarding future growth of the markets in which we operate.
- our expectations regarding the rates of adoption of alternative energy sources.
- our expectations regarding the decline in prices of battery energy storage systems.
- potential product liability claims.
- competition from existing competitors and the potential emergence of new competitors.
- our belief regarding competitive factors in the markets in which we operate and our belief regarding our ability to compete effectively in those markets.

These statements reflect our views with respect to future events as of the date of this prospectus supplement and are based on assumptions and subject to risks and uncertainties. Given these uncertainties, you should not place undue reliance on these forward-looking statements. The forward-looking statements in this prospectus supplement, the accompanying prospectus and the documents incorporated by reference into this prospectus supplement represent our estimates and assumptions only as of the date of this prospectus supplement and, except as required by law, we undertake no obligation to update or review publicly any forward-looking statements, whether as a result of new information, future events or otherwise after the date of this prospectus supplement. We anticipate that subsequent events and developments will cause our views to change. You should read this prospectus supplement, the accompanying prospectus and other documents incorporated by reference herein and filed as exhibits to the registration statement, of which this prospectus supplement and the accompanying prospectus are a part, completely and with the understanding that our actual future results may be materially different from what we expect. Our forward-looking statements do not reflect the potential impact of any future acquisitions, merger, dispositions, joint ventures or investments we may undertake. We qualify all of our forward-looking statements by these cautionary statements.

PROSPECTUS SUPPLEMENT SUMMARY

This summary highlights selected information about us, this offering and information contained elsewhere in this prospectus supplement, in the accompanying prospectus and in the documents we incorporate by reference. For a more complete understanding of our company and this offering, we encourage you to read and consider carefully the more detailed information contained in or incorporated by reference in this prospectus supplement and the accompanying prospectus, including the information contained under the heading “Risk Factors” beginning on page S-4 of this prospectus supplement, and the information included in any free writing prospectus that we have authorized for use in connection with this offering.

Unless the context otherwise requires, all references in this prospectus to “Ideal Power,” “we,” “us,” “our,” “the Company” or similar words refer to Ideal Power Inc.

Business Overview

Overview

We design, market and sell electrical power conversion products using our proprietary technology called Power Packet Switching Architecture, or PPSA. Our PPSA technology enables high efficiency power conversion by eliminating many of the heavy, passive components used in conventional power conversion products and replacing them with computing and switching technologies. Our products are designed to be used in both on-grid and off-grid applications. We believe our products are the only transformer-less power converters approved for use in on-grid applications. Our PPSA technology is protected by a patent portfolio of 21 US and four foreign patents. We own all of the rights to our PPSA technology.

We sell our products primarily to systems integrators for installation as part of a larger turn-key system providing the end user with a complete solution for managing their energy consumption. These customers sell systems that enable end users to manage their electricity consumption by reducing demand charges and integrating renewable energy sources. We also sell systems to commercial end users that enable them to reduce fossil fuel consumption, and form their own microgrid. Our products are made by contract manufacturers to our specifications, enabling us to scale production to meet demand on a cost-effective basis without requiring significant expenditures on manufacturing facilities and equipment. Most of our existing products that connect to the power grid are UL 1741 certified, and we are in the process of getting the others UL 1741 certified.

Our PPSA Technology

Our PPSA-based products provide the same electrical isolation as traditional, transformer-based power conversion systems. We believe our products are the only commercial transformer-less power conversion systems that provide the electrical isolation required to connect alternative energy sources and battery storage systems to the grid. Because our products use computing and switching technologies to replace the traditional transformer and other bulky, passive components used in traditional power conversion systems, our power conversion systems are lighter, smaller and more efficient.

Our PPSA technology uses indirect power flow in which power flows through input switches and is temporarily stored in our proprietary AC link inductor. Our proprietary fast switching algorithms enable the transfer of quantum packets of power between ports in our system. As the AC link becomes charged, it disconnects from its input switches, resonates without being connected to either the input or output switches, and then reconnects to its output switches when it reaches the correct voltage and frequency for the application, providing true electrical isolation without the need for a transformer.

Existing Products

We have six products based on our PPSA technology currently in production. Each of these products is briefly described below:

- 30kW photovoltaic, or PV, Inverter, which has a UL 1741 certification and is intended to be used for commercial and industrial solar power installations. This is our first product and shares the same hardware as the Company’s 30kW battery converter described below but uses embedded software specific to a PV application.
- 30kW Battery Converter, which has a UL 1741 certification and is intended to be used for commercial and industrial grid-tied distributed energy storage market. This battery converter is bi-directional, which means it can distribute power to or from a BESS array. This product uses the same hardware design as the 30kW PV Inverter, but has embedded software that enables bi-directional power conversion and control. This product is more efficient and approximately only 1/5th the size and weight of similar transformer-based products. The 30kW Battery Converter also has a significantly lower acoustic noise profile and can be installed in buildings without the need for acoustic isolation or insulation.
- 30kW grid-resilient AC-DC power conversion system. This product is able to convert to both 50Hz and 60Hz AC current and has the ability to form and manage a microgrid. It is intended for use by customers who are interested in our existing 30kW battery converter but need to use the product overseas or need the additional capability to form a microgrid. This product is not a replacement for our 30kW battery converter but complements the existing product with additional features.

- 30kW grid-resilient AC-DC-DC multi-port power conversion system with two DC ports enabling two DC inputs, such as a PV and a battery storage system, to be installed with one power converter. This product is capable of managing the conversion to both 50Hz and 60Hz AC current, enabling the ability to operate in grids outside of North America. This product also has the ability to form and manage a microgrid, effectively using energy storage with distributed generation resources to support critical loads or allow a building to disconnect from the utility power grid. We expect to receive UL 1741 certification for grid-tied applications of this product in the second quarter 2015. This product received the “Electrical Energy Storage Award” for product innovation at InterSolar, Germany, the world’s largest solar exhibition.
- 125kW grid-resilient AC-DC power conversion system, for higher power applications. This 125kW system has over four times the power of the 30kW product and is also able to convert to both 50Hz and 60Hz AC current. This product is primarily for use in grid-tied applications, and we expect to receive its UL 1741 certification in the second half of 2015. It also has the ability to form and manage a microgrid.
- 125kW grid-resilient AC-DC-DC multi-port power conversion system for higher power applications with multi-port capabilities. This 125kW system has over four times the power of the 30kW multi-port product and is also able to convert to both 50Hz and 60Hz AC current. This product has the ability to form and manage a microgrid. Because this product is intended primarily for off-grid and microgrid management applications, we do not intend to seek a UL 1741 certification for this product at this time. This product is currently in prototype production only with the first customer shipment scheduled for May 2015.

The figure below illustrates this product family:



Implications of Being an Emerging Growth Company

We are an “emerging growth company,” as defined in the Jumpstart Our Business Startups Act of 2012, or the JOBS Act, and, for as long as we continue to be an “emerging growth company,” we may choose to take advantage of exemptions from various reporting requirements applicable to other public companies but not to “emerging growth companies,” including, but not limited to, not being required to comply with the auditor attestation requirements of Section 404 of the Sarbanes-Oxley Act of 2002, reduced disclosure obligations regarding executive compensation in our periodic reports and proxy statements, and exemptions from the requirements of holding a nonbinding advisory vote on executive compensation and stockholder approval of any golden parachute payments not previously approved. We could be an “emerging growth company” for up to five years, or until the earliest of (i) the last day of the first fiscal year in which our annual gross revenues exceed \$1 billion, (ii) the date that we become a “large accelerated filer” as defined in Rule 12b-2 under the Securities Exchange Act of 1934, as amended, which would occur if the market value of our common stock that is held by non-affiliates exceeds \$700 million as of the last business day of our most recently completed second fiscal quarter, or (iii) the date on which we have issued more than \$1 billion in non-convertible debt during the preceding three-year period. We are choosing to “opt out” of the extended transition periods available under the JOBS Act for complying with new or revised accounting standards, and intend to take advantage of the other exemptions.

Corporate Information

We were initially formed in Texas on May 17, 2007. We were formerly known as Ideal Power Converters, Inc. The Company changed its name to Ideal Power Inc. on July 8, 2013 and re-incorporated in Delaware on July 15, 2013. Our corporate offices are located at 4120 Freidrich Lane, Suite 100, Austin, Texas 78744. Our telephone number is (512) 264-1542. We maintain an Internet website at www.idealpower.com. The contents on our website are not part of this prospectus, and the reference to our website does not constitute incorporation by reference into this prospectus of the information contained at that site.

THE OFFERING

Common stock we are offering	1,935,500 shares of our common stock
Common stock outstanding immediately prior to this offering	7,066,137 shares ⁽¹⁾
Common stock outstanding immediately after this offering	9,001,637 shares ⁽¹⁾
Use of proceeds	We intend to use the net proceeds of this offering for working capital and general corporate purposes. Please see "Use of Proceeds" on page S-14.
Risk factors	An investment in our common stock involves significant risks. See "Risk Factors" beginning on page S-4 of this prospectus supplement for a discussion of risks you should carefully consider before investing in our securities.
Listing	Our common stock is listed on The NASDAQ Capital Market, or NASDAQ, under the symbol "IPWR."

(1) The number of shares of our common stock outstanding prior to and to be outstanding immediately after this offering, as set forth in the above table, is based on 7,066,137 shares of common stock outstanding as of March 31, 2015 and excludes, as of that date:

- 1,387,186 shares of common stock issuable upon the exercise of outstanding stock options, having a weighted average exercise price of \$6.51 per share;
- 1,564,108 shares of our common stock issuable upon the exercise of outstanding warrants with a weighted-average exercise price of \$4.48 per share; and
- 135,677 shares available for future grant under our 2013 Equity Incentive Plan.

Unless we specifically state otherwise, the information in this prospectus supplement assumes no exercise by the underwriters of their option to purchase additional shares of our common stock in this offering within 30 days after the date of this prospectus supplement.

RISK FACTORS

An investment in our securities involves a substantial risk of loss. You should carefully consider these risk factors, together with all of the other information included or incorporated by reference in this prospectus supplement and the accompanying prospectus, before you decide to invest in our securities. The occurrence of any of the following risks could harm our business. In that case, the trading price of our common stock could decline, and you may lose all or part of your investment. Additional risks and uncertainties not presently known to us or that we currently deem immaterial may also impair our operations. You should also refer to the other information contained in this prospectus supplement and the accompanying prospectus or incorporated by reference herein and therein, including our financial statements and the notes to those statements and the information set forth under the heading "Cautionary Note Regarding Forward-Looking Statements."

Risks Related to the Company

We lack an established operating history on which to evaluate our business and determine if we will be able to execute our business plan, and we can give no assurance that our operations will result in profits.

We were formed in Texas on May 17, 2007 and converted to a Delaware corporation on July 15, 2013. We have a limited operating history that makes it difficult to evaluate our business. Historical sales of our products have been in low volume, and we cannot say with certainty when we will begin to achieve profitability. No assurance can be made that we will ever become profitable.

We have incurred losses in prior periods and expect to incur losses in the future. We may never be profitable.

Since our inception on May 17, 2007 through March 31, 2015, we have sustained \$25,845,429 in net losses and we had net losses for the years ended December 31, 2014 and 2013 of \$6,900,219 and \$9,551,698, respectively and net losses for the three months ended March 31, 2015 and 2014 of \$2,192,998 and \$1,420,742, respectively. We expect to have operating losses at least until such time as we have developed a substantial and stable revenue base. We cannot assure you that we can develop a substantial and stable revenue base or achieve or sustain profitability on a quarterly or annual basis in the future.

As sales of our products have generated minimal operating revenues, we have relied on borrowings under convertible promissory notes, governmental grants and, recently, proceeds from our initial public offering to continue our operations. If we are unable to implement our business plan, generate sustainable revenue and achieve profitable operations with our existing capital we would need to raise funds through equity or debt offerings and there can be no assurance that we will be able to do so.

To date we have had a limited number of customers. We cannot assure you that our customer base will increase.

One customer, the Department of Energy, from which we received \$579,079 and \$1,229,036 in grant revenues in 2014 and 2013, respectively, accounted for 32% and 65% of net revenue for the years ended December 31, 2014 and 2013, respectively, while our three largest customers for product sales, from whom we received \$789,000 in product revenues in 2014, accounted for 20%, 13% and 11% of net revenues in 2014. Three customers for product sales represented 44% of our net product revenues in 2014. As a significant portion of our 2013 and 2014 net revenue was from a single customer under grant programs that have been fully funded, we cannot assure you that we will have significant grant revenue in the future. Also, as the Company has sold its products to a limited number of customers in 2013 and 2014, we cannot assure you that our customer base will expand or that any decline in net revenue attributable to customer losses will be able to be replaced in a timely manner.

We may not be able to meet our product development and commercialization milestones.

Product development and testing are subject to unanticipated and significant delays, expenses and technical or other problems. We cannot guarantee that we will successfully achieve our milestones within our planned timeframe or ever. Our plans and ability to achieve profitability depend on acceptance of our technology and our products by key market participants, such as customers, vendors and marketing partners, and potential end-users of our products. We continue to educate potential partners about our PPSA technology and current and planned product offerings. More generally, the commercialization of our products may also be adversely affected by many factors not within our control, including:

- the willingness of market participants to try a new product and the perceptions of these market participants of the safety, reliability, functionality and cost effectiveness of our products;
- the emergence of newer, possibly more effective technologies;
- the future cost and availability of the raw materials and components needed to manufacture and use our products; and
- the adoption of new regulatory or industry standards that may adversely affect the use or cost of our products.

Accordingly, we cannot predict that our products will be accepted on a scale sufficient to support development of mass markets for them.

We must achieve design wins to retain our existing customers and to obtain new customers, although design wins achieved do not necessarily result in substantial sales.

The constantly changing nature of technology in the markets we serve causes equipment manufacturers to continually design new systems. We must work with these manufacturers early in their design cycles to modify our equipment or design new equipment to meet the requirements of their new systems. Manufacturers typically choose one or two vendors to provide the components for use with early system shipments. Selection as one of these vendors is called a design win. It is critical that we achieve these design wins in order to retain existing customers and to obtain new customers.

We believe that equipment manufacturers often select their suppliers based on factors including long-term relationships and end user demand. Accordingly, we may have difficulty achieving design wins from equipment manufacturers who are not currently our customers. In addition, we must compete for design wins for new systems and products of our existing customers, including those with whom we have had long-term relationships. Our efforts to achieve design wins are time consuming, expensive, and may not be successful. If we are not successful in achieving design wins, or if we do achieve design wins but our customers' systems that utilize our products are not successful, our business, financial condition, and results of operations could be materially and adversely impacted.

Once a manufacturer chooses a component for use in a particular product, it is likely to retain that component for the life of that product. Our sales and growth could experience material and prolonged adverse effects if we fail to achieve design wins. However, design wins do not always result in substantial sales, as sales of our products are dependent upon our customers' sales of their products.

The prototype of any planned products may not provide the results we expect, may prove to be too expensive to produce and market, or may uncover problems of which we are currently not aware, any of which could harm our business and prospects.

We commonly develop prototypes of planned products prior to the full commercialization of these products. As an example, we developed a 3-port hybrid converter, which is an integrated solar PV inverter and battery charger/inverter and which we now refer to as a grid-resilient 30kW multi-port power conversion system, during 2013 and 2014 and shipped a prototype of this product to a customer in July 2014. Although this prototype produced positive results consistent with our expectations, we cannot predict whether prototypes of future products will achieve results consistent with our expectations. A prototype could cost significantly more than expected or the prototype design and construction process could uncover problems that are not consistent with our expectations. Prototypes of emerging products are a material part of our business plan, and if they are not proven to be successful, our business and prospects could be harmed.

We have received grant funds from the United States for the development of a bi-directional insulated-gate bipolar transistor, or BD-IGBT. In certain instances, the United States may obtain title to inventions related to this effort. If we were to lose title to those inventions, we may have to pay to license them from the United States in order to manufacture the BD-IGBT. If we were unable to license those inventions from the United States, it could slow down our product development.

In conjunction with the Advanced Research Projects Agency-Energy, or ARPA-E, grant we received from the Department of Energy, we granted to the United States a non-exclusive, nontransferable, irrevocable, paid-up license to practice or have practiced for or on behalf of the United States inventions related to the BD-IGBT and made within the scope of the grant. If we fail to disclose to the Department of Energy an invention made with grant funds that we disclose to patent counsel or for publication, or if we elect not to retain title to the invention, the United States may request that title to the subject invention be transferred to it.

We also granted "march-in-rights" to the United States in connection with any BD-IGBT inventions in which we choose not to retain title, if those inventions are made under the ARPA-E grant. Pursuant to the march-in-rights, the United States has the right to require us, any person to whom we have assigned our rights, or any exclusive licensee to grant a non-exclusive, partially exclusive, or exclusive license in any field of use to a responsible applicant upon terms that are reasonable. If the license is not granted as requested, the United States has the right to grant the license if it determines that we have not achieved practical application of the invention in the field of use, the action is necessary to alleviate health or safety needs, the action is necessary to meet requirements for public use specified by Federal regulations and such requirements have not been satisfied, or the action is necessary because an agreement to manufacture the invention in the United States has not been obtained or waived or because any such agreement has been breached.

If we lost title to the United States as a result of any of these events, we would have to pay to license the inventions, if needed, to manufacture the BD-IGBT from the United States. If we were unable to license those inventions from the United States, it could slow down our product development.

As we continue to grow and to develop our intellectual property, we could attract threats from patent monetization firms or competitors alleging infringement. We may incur substantial costs as a result of litigation or other proceedings relating to patent and other intellectual property rights.

As we continue to grow and to develop our intellectual property, we could attract threats from patent monetization firms or competitors alleging infringement of intellectual property rights. For example, on October 4, 2013 we received a letter from a competitor alleging that the system architecture that appears on our website “appears” to infringe on patents licensed to or held by the competitor. We have investigated this claim and we have determined that the allegation is without merit. No resolution regarding this assertion has been reached. In early 2014, we met with the competitor to discuss the issue. No subsequent discussions have been held with, and no further correspondence has been received from this competitor. If we cannot resolve this matter, the cost to us of any litigation or other proceeding relating to intellectual property rights, even if resolved in our favor, could be substantial, and the litigation would divert management’s attention from our day-to-day operations.

In addition, some of our competitors may be able to sustain the costs of complex patent litigation more effectively than we can because they have substantially greater resources. If we do not prevail in this type of litigation, we may be required to: pay monetary damages; stop commercial activities relating to our product; obtain one or more licenses in order to secure the rights to continue manufacturing or marketing certain products; or attempt to compete in the market with substantially similar products. Uncertainties resulting from the initiation and continuation of any litigation could limit our ability to continue some of our operations.

We expect to license our technology in the future; however the terms of these agreements may not prove to be advantageous to us. If the license agreements we enter into do not prove to be advantageous to us, our business and results of operations will be adversely affected.

We expect to license the manufacture of our product designs for certain markets as well as license our technology for certain potential applications which we choose not to pursue directly through the sale of products. However, we may not be able to secure license agreements with customers on terms that are advantageous to us. Furthermore, the timing and volume of revenue earned from license agreements will be outside of our control. If the license agreements we enter into do not prove to be advantageous to us, our business and results of operations will be adversely affected.

Until recently, we have not devoted significant resources towards the marketing and sale of our products and we continue to rely on the marketing and sales efforts of third parties whom we do not control.

To date, we have sold low volumes of our battery converter and power conversion system products. We expect that the marketing and sale of these products to end user customers will continue to be conducted primarily by a combination of independent manufacturers’ representatives, third-party strategic partners, distributors, or original equipment manufacturers, or OEMs. Consequently, commercial success of our products will depend to a great extent on the efforts of others. We intend to enter into strategic marketing and distribution agreements or other collaborative relationships to market and sell our products. However, we have entered into only a limited number of strategic marketing or material distribution agreements at this time. We have recently entered into one distribution agreement with a large electrical equipment distributor, obtained initial orders from this distributor and shipped products under these initial orders to this distributor. We may not be able to identify or establish additional and/or appropriate relationships in the near term or in the future. We can give no assurance that these distributors or OEMs will focus adequate resources on selling our products or will be successful in selling them. In addition, third-party distributors or OEMs have or may require us to provide volume price discounts and other allowances, customize our products or provide other concessions that could reduce the potential profitability of these relationships. Failure to develop sufficient distribution and marketing relationships in our target markets will adversely affect our commercialization schedule and to the extent we have entered or enter into such relationships, the failure of our distributors and other third parties to assist us with the marketing and distribution of our products, or to meet their monetary obligations to us, may adversely affect our financial condition and results of operations.

A material part of our success depends on our ability to manage our suppliers and manufacturers. Our failure to manage our suppliers and manufacturers could materially and adversely affect our results of operations and relations with our customers.

We rely upon suppliers to provide the components necessary to build our products and on contract manufacturers to produce our products. There can be no assurance that key suppliers and manufacturers will provide components or products in a timely and cost efficient manner or otherwise meet our needs and expectations. Our ability to manage such relationships and timely replace suppliers and manufacturers, if necessary, is critical to our success. Our failure to timely replace our contract manufacturers and suppliers, should that become necessary, could materially and adversely affect our results of operations and relations with our customers.

Our business may be dependent upon our ability to obtain financing. If we do not obtain such financing, we may have to cease our activities.

There is no assurance that we will operate profitably or generate positive cash flows in the future. In the future, we may require additional financing in order to sell our then current products and to continue the research and development required to produce our next generation of products. At that time, we may not be able to obtain financing on commercially reasonable terms or at all. If we do not obtain such financing when needed, our business could fail.

The macro-economic environment in the United States and abroad has adversely affected, and may in the future adversely affect, our ability to raise capital, which may potentially impact our ability to continue our operations.

As a company with limited revenues to date, we may need to rely on raising funds from investors to support our future research and development activities and our operations. Macro-economic conditions in the United States and abroad may result in a tightening of the credit markets and/or less capital available for small public companies, which may make it more difficult to raise capital. If we are unable to raise funds as and when we need them, we may be forced to curtail our operations or even cease operating altogether.

We are subject to credit risks.

Some of our customers may experience financial difficulties and/or may fail to meet their financial obligations to us. As a result, we may incur charges for bad debt provisions related to some trade receivables. In addition, in connection with the growth of the renewable energy market and other markets for our products, we are gaining new customers, some of which have relatively short histories of operations or are newly formed companies. As a result, it is difficult to ascertain financial information in order to appropriately extend credit to these customers. Further, the volatility in the renewable energy market may put additional pressure on our customers' financial positions, as they may be required to respond to large swings in revenue. The renewable energy industry has also seen an increasing amount of bankruptcies and reorganizations as the availability of financing has diminished.

If customers fail to meet their financial obligations to us, or if the assumptions underlying our recorded bad debt provisions with respect to receivables obligations do not accurately reflect our customers' financial conditions and payment levels, we could incur write-offs of receivables in excess of our provisions, which could have a material adverse effect on our cash flow and operating results.

We may not be able to control our warranty exposure, which could increase our expenses.

We currently offer and expect to continue to offer a warranty with respect to our products and we expect to offer a warranty with each of our future product applications. Due to our limited long-term history of operating data, our reserve is estimated based on engineering judgment and a third party assessment of our product reliability. If the cost of warranty claims exceeds any reserves we may establish for such claims, our results of operations and financial condition could be adversely affected.

We may be exposed to lawsuits and other claims if our products malfunction, which could increase our expenses, harm our reputation and prevent us from growing our business.

Any liability for damages resulting from malfunctions of our products could be substantial, increase our expenses and prevent us from growing or continuing our business. Potential customers may rely on our products for critical needs, such as backup power. A malfunction of our products could result in warranty claims or other product liability. In addition, a well-publicized actual or perceived problem could adversely affect the market's perception of our products. This could result in a decline in demand for our products, which would reduce revenue and harm our business. Further, since our products are used in devices that are made by other manufacturers, we may be subject to product liability claims even if our products do not malfunction.

We are highly dependent on the services of R. Daniel Brdar and William Alexander, as well as other key members of our executive management team. Our inability to retain these individuals could impede our business plan and growth strategies, which could have a negative impact on our business and the value of your investment.

Our ability to implement our business plan depends, to a critical extent, on the continued efforts and services of R. Daniel Brdar, our Chief Executive Officer and President, William Alexander, our founder and Chief Technology Officer, and other members of our executive management team. If we lose the services of any of these persons during this important time in our development, the loss may result in a delay in the implementation of our business plan and plan of operations. We can give no assurance that we could find satisfactory replacements for these individuals on terms that would not be unduly expensive or burdensome to us. We do not currently carry a key-man life insurance policy that would assist us in recouping our costs in the event of the death or disability of any of these persons.

Any failure by management to properly manage our expected rapid growth could have a material adverse effect on our business, operating results and financial condition.

If our business develops as expected, we anticipate that we will grow rapidly in the near future. Our failure to properly manage our expected rapid growth could have a material adverse effect on our ability to retain key personnel. Our expansion could also place significant demands on our management, operations, systems, accounting, internal controls and financial resources. If we experience difficulties in any of these areas, we may not be able to expand our business successfully or effectively manage our growth. Any failure by management to manage growth and to respond to changes in our business could have a material adverse effect on our business, financial condition and results of operations.



Backlog may not result in revenue.

The Company's backlog of released and firm orders was approximately \$1.9 million at March 31, 2015. The Company defines backlog as consisting of accepted orders from customers for which a product delivery schedule has been specified. The purchase orders comprising backlog are not cancellable in most cases and such orders do not provide price protection. Nevertheless, deliveries against received purchase orders may be rescheduled or cancelled with our consent, and our backlog may therefore not be indicative of revenues in any given period.

Risks Relating to the Industry

The electric power conversion industry is competitive and has a number of well-financed incumbents. We cannot guarantee that it can compete successfully.

Ideal Power competes against providers of power conversion systems that are well established and have substantially greater assets, including manufacturing, marketing, and financial assets. These incumbents also have strong market share and name brand recognition in the industry. Competitors include ABB, Ltd., Eaton Corporation plc, SMA Solar Technology AG, and Schneider Electric SE. Pricing, financing, servicing, as well as the general quality, efficiency and reliability of products, are significant competitive criteria in this industry. The Company's ability to successfully compete on each of these criteria is material to the acceptance of its products and its future profitability. In addition, the industry may resist new technology and products from suppliers that are not well capitalized with long track records of performance. Our competitors use their balance sheet and brand recognition to their competitive advantage. Should our products become commercially successful, competitors may seek to drive their own innovation and adopt or copy ideas, designs and features to regain their competitive positions. Competitors may develop or offer technologies and products that may be more effective or popular than the Company's products and they may be more successful in marketing their products than we are in marketing its own products. Additionally, price competition may result in lower than expected margins for our products.

We expect to compete on the basis of its products' lower cost, smaller footprint, higher efficiency, and technological innovation, flexibility and features. Unrelated technological advances in alternative energy products or other power conversion technologies may negatively impact the development of the Company's products or make the Company's products uncompetitive or obsolete at any time. We cannot guaranty that it will be able to compete successfully in the electric power conversion industry.

The reduction or elimination of government subsidies and economic incentives for energy-related technologies could harm our business.

We believe that near-term growth of energy-related technologies, including power conversion technology, relies partly on the availability and size of government and economic incentives and grants (including, but not limited to, the U.S. Investment Tax Credit and various state and local incentive programs). These incentive programs could be challenged by utility companies, or for other reasons found to be unconstitutional, and/or could be reduced or discontinued for other reasons. The reduction, elimination, or expiration of government subsidies and economic incentives could delay the development of our technology and harm our business.

Changes to the National Electrical Codes could adversely affect our technology and products.

Our products are installed by system integrators that must meet the National Electrical Codes, or NEC, standards, including using equipment that meets industry standards such as UL1741. The NEC standards address the safety of these systems. The NEC standards, along with the UL1741 and IEEE1547 requirements, continue to evolve and are subject to change. If we respond to these changing standards and requirements more slowly than our competitors, or if we are unable to meet new standards and requirements, our products will be less competitive.

New technologies in the alternative energy industry may supplant our current products and technology in this market, which would harm our business and operations.

The alternative energy industry is subject to rapid technological change. Our future success will depend on the cutting edge relevance of our technology, and thereafter on our ability to appropriately respond to changing technologies and changes in function of products and quality. If new technologies supplant our power conversion technology, our business would be adversely affected and we will have to revise our plan of operation.

Businesses, consumers, and utilities might not adopt alternative energy solutions as a means for providing or obtaining their electricity and power needs.

On-site distributed power generation solutions that utilize our products provide an alternative means for obtaining electricity and are relatively new methods of obtaining electrical power. There is a risk that businesses, consumers, and utilities may not adopt these new methods at levels sufficient to grow our business. Traditional electricity distribution is based on the regulated industry model whereby businesses and consumers obtain their electricity from a government regulated utility. For alternative methods of distributed power to succeed, businesses, consumers and utilities must adopt new purchasing practices and must be willing to rely upon less traditional means of providing and purchasing electricity. As larger solar projects come online, utilities are becoming increasingly concerned with grid stability, power management and the predictable loading of such power onto the grid.

We cannot be certain that businesses, consumers, and utilities will choose to utilize on-site distributed power at levels sufficient to sustain our business. The development of a mass market for our products may be impacted by many factors which are out of our control, including:

- market acceptance of systems that incorporate our products;
- the cost competitiveness of these systems;
- regulatory requirements; and
- the emergence of newer, more competitive technologies and products.

If a mass market fails to develop or develops more slowly than we anticipate, we may be unable to recover the costs we will have incurred to develop these products.

The industries in which we compete are subject to volatile and unpredictable cycles.

As a supplier to the grid energy storage, solar combined with storage, microgrid, and related industries, we may be subject to business cycles. The timing, length, and volatility of these business cycles may be difficult to predict. These industries may be cyclical due to sudden changes in customers' manufacturing capacity requirements and spending, which depend in part on capacity utilization, demand for customers' products, inventory levels relative to demand, and access to affordable capital. These changes may affect the timing and amounts of customers' purchases and investments in technology, and affect our orders, net sales, operating expenses, and net income. In addition, we may not be able to respond adequately or quickly to the declines in demand by reducing our costs. We may be required to record significant reserves for excess and obsolete inventory as demand for our products changes.

To meet rapidly changing demand in each of the industries we serve, we must effectively manage our resources and production capacity. During periods of decreasing demand for our products, we must be able to appropriately align our cost structure with prevailing market conditions, effectively manage our supply chain, and motivate and retain key employees. During periods of increasing demand, we must have sufficient manufacturing capacity and inventory to fulfill customer orders, effectively manage our supply chain, and attract, retain, and motivate a sufficient number of qualified individuals. If we are not able to timely and appropriately adapt to changes in our business environment or to accurately assess where we are positioned within a business cycle, our business, financial condition, or results of operations may be materially and adversely affected.

Our business is substantially dependent on utility rate structures and government incentive programs that encourage the use of alternative energy sources. Any change in these rate structures or incentive programs could affect the demand for our products.

A combination of utility rate structures and government subsidies that encourage the use of alternative energy sources drives demand for our products. For example, public utilities are often allowed to collect demand charges on commercial and industrial customers in addition to traditional usage charges. In addition, the federal government and many states encourage the use of alternative energy sources through a combination of direct subsidies and tariff incentives such as net metering for users that use alternative energy sources such as solar power. California also encourages alternative energy technology through its Self-Generation Incentive Program, or SGIP, which offers rebates for consumers who adopt new technology, including energy storage. As a result of these incentives, we believe that a substantial portion of the products we have sold have been for use by customers in California. Other states have similar incentives and mandates which encourage the adoption of alternative energy sources. Notwithstanding the adoption of other incentive programs, we expect that sales of our products will continue to be geographically concentrated in California in the near term. Should California or another state in which we derive a substantial portion of our product revenues in the future changes its utility rate structure or eliminates or significantly reduces its incentive programs, demand for our products could be substantially affected, which would adversely affect our business prospects, financial condition and operating results.

Our sales cycle is lengthy and variable, which makes it difficult for us to accurately forecast revenue and which may affect our quarterly results.

The sales cycle for our products is lengthy and unpredictable, which makes it difficult for us to accurately forecast revenues in a given period, and may cause revenue and operating results to vary significantly from period to period. We currently sell our products primarily to system integrators that integrate our products into larger "turn-key" solutions for their customers. Before a system integrator agrees to specify our products in their systems, the integrator engages in a lengthy and time-consuming process of testing and evaluating our equipment for use. This process can take from six months to over a year. Even if our products are approved for use by a system integrator, the system integrator may not place an order for our equipment until the system integrator has entered into a contract with the end user for the design and installation of the system. In many cases, the system integrator is required to respond to a detailed request for proposal or to submit a proposal before a contract for the system is executed. Although we maintain a small finished goods inventory, in most cases products are produced for us by our contract manufacturer in response to a particular customer order. As a result, there may be a significant period of time between the time our products are approved for use by a particular system integrator and the time we record revenue from the sale of our products. As a result of our lengthy sales cycles, we may have difficulty in accurately predicting our operating results for any given period, and may experience significant unanticipated fluctuations in our revenues from period to period. Any failure to achieve anticipated revenues for a period could adversely affect our operating results and the market price of our common stock.

Our revenue and operating results for any quarterly reporting period may fluctuate significantly depending on the timing of the delivery of our products.

Our revenue from product sales through March 31, 2015 has resulted from the sale of a relatively small number of units. As a result, a small change in the expected delivery date for a particular customer order could have a significant impact on our quarterly revenues and operating results. Although we maintain a small finished goods inventory, in most cases products are produced for us by our contract manufacturer in response to a particular customer order. Because of our lengthy sales cycle and manufacturing lead times, we may not be able to accurately predict the timing of the delivery of a particular order. Significant unanticipated fluctuations in our revenues from period to period could adversely affect our operating results and the market price for our common stock.

Risks Related to Owning Our Common Stock

We are an “emerging growth company” under the Jumpstart Our Business Startups Act of 2012 and we cannot be certain if the reduced disclosure requirements applicable to emerging growth companies will make our common stock less attractive to investors.

We are an “emerging growth company,” as defined in the Jumpstart Our Business Startups Act of 2012, or the JOBS Act, and we may take advantage of certain exemptions from various reporting requirements that are applicable to other public companies that are not “emerging growth companies” including, but not limited to, not being required to comply with the auditor attestation requirements of section 404 of the Sarbanes-Oxley Act of 2012, or the Sarbanes-Oxley Act, reduced disclosure obligations regarding executive compensation in our periodic reports and proxy statements, and exemptions from the requirements of holding a nonbinding advisory vote on executive compensation and stockholder approval of any golden parachute payments not previously approved. At present, we intend to take advantage of the exemption from the requirement of holding a nonbinding advisory vote on executive compensation but do not intend to take advantage of any of the other exemptions, other than as they apply to all other “smaller reporting companies,” though we may do so at some point in the future. We cannot predict if investors will find our common stock less attractive because we may rely on these exemptions. If some investors find our common stock less attractive as a result, there may be a less active trading market for our common stock and our stock price may be more volatile.

We will remain an “emerging growth company” for up to five years, although we will lose that status sooner if our revenues exceed \$1 billion, if we issue more than \$1 billion in non-convertible debt in a three year period, or if the market value of our common stock that is held by non-affiliates exceeds \$700 million as of any June 30.

Our status as an “emerging growth company” under the JOBS Act may make it more difficult to raise capital as and when we need it.

Because of the exemptions from various reporting requirements provided to us as an “emerging growth company,” we may be less attractive to investors and it may be difficult for us to raise additional capital as and when we need it. Investors may be unable to compare our business with other companies in our industry if they believe that our reporting is not as transparent as other companies in our industry. If we are unable to raise additional capital as and when we need it, our financial condition and results of operations may be materially and adversely affected.

The public market for our common stock may be volatile. This may affect the ability of our investors to sell their shares as well as the price at which they sell their shares.

The market price for the shares may be significantly affected by factors such as variations in the volume of trading activity, quarterly and yearly operating results, general trends in the alternative energy industry or other markets we serve, and changes in state or federal regulations affecting us and our industry. Furthermore, in recent years the stock market has experienced extreme price and volume fluctuations that are unrelated or disproportionate to the operating performance of the affected companies. Such broad market fluctuations may adversely affect the market price of our common stock.

We have the right to issue shares of preferred stock. If we were to issue preferred stock, it is likely to have rights, preferences and privileges that may adversely affect the common stock.

We are authorized to issue 10,000,000 shares of “blank check” preferred stock, with such rights, preferences and privileges as may be determined from time-to-time by our board of directors. Our board of directors is empowered, without stockholder approval, to issue preferred stock in one or more series, and to fix for any series the dividend rights, dissolution or liquidation preferences, redemption prices, conversion rights, voting rights, and other rights, preferences and privileges for the preferred stock. No shares of preferred stock are presently issued and outstanding and we have no plans to issue shares of preferred stock. The issuance of shares of preferred stock, depending on the rights, preferences and privileges attributable to the preferred stock, could reduce the voting rights and powers of the common stock and the portion of the Company’s assets allocated for distribution to common stockholders in a liquidation event, and could also result in dilution in the book value per share of the common stock we are offering. The preferred stock could also be utilized, under certain circumstances, as a method for raising additional capital or discouraging, delaying or preventing a change in control of the Company, to the detriment of the investors in the common stock offered hereby. We cannot assure you that we will not, under certain circumstances, issue shares of our preferred stock.

We have not paid dividends in the past and have no immediate plans to pay dividends.

We plan to reinvest all of our earnings, to the extent we have earnings, in order to market our products and to cover operating costs and to otherwise become and remain competitive. We do not plan to pay any cash dividends with respect to our securities in the foreseeable future. We cannot assure you that we would, at any time, generate sufficient surplus cash that would be available for distribution to the holders of our common stock as a dividend. Therefore, you should not expect to receive cash dividends on our common stock.

Management of our Company is within the control of the board of directors and the officers. You should not purchase our common stock unless you are willing to entrust management of our Company to these individuals.

All decisions with respect to the management of the Company will be made by our board of directors and our officers, who beneficially own 11.8% of our common stock, as calculated in accordance with Rule 13d-3 promulgated under the Securities Exchange Act of 1934, as amended, or the Exchange Act. Therefore, management will retain significant influence in electing a majority of the board of directors who shall, in turn, have the power to appoint the officers of the Company and to determine, in accordance with their fiduciary duties and the business judgment rule, the direction, objectives and policies of the Company including, without limitation, the purchase of businesses or assets; the sale of all or a substantial portion of the assets of the Company; the merger or consolidation of the Company with another corporation; raising additional capital through financing and/or equity sources; the retention of cash reserves for future product development, expansion of our business and/or acquisitions; the filing of registration statements with the Securities and Exchange Commission for offerings of our capital stock; and transactions that may cause or prevent a change in control of the Company or its winding up and dissolution. Accordingly, no investor should purchase our common stock unless such investor is willing to entrust all aspects of the management of the Company to such individuals.

We have incurred significant increased costs as a result of becoming a public company that reports to the Securities and Exchange Commission and our management is required to devote substantial time to meet compliance obligations.

As a public company reporting to the Securities and Exchange Commission, we incur significant legal, accounting and other expenses that we did not incur as a private company. We are subject to reporting requirements of the Exchange Act and the Sarbanes-Oxley Act, as well as rules subsequently implemented by the Securities and Exchange Commission that impose significant requirements on public companies, including requiring establishment and maintenance of effective disclosure and financial controls and changes in corporate governance practices. In addition, there are significant corporate governance and executive compensation-related provisions in the Dodd-Frank Act that are expected to increase our legal and financial compliance costs, make some activities more difficult, time-consuming or costly and may also place undue strain on our personnel, systems and resources. Our management and other personnel are required to devote a substantial amount of time to these and other new compliance initiatives. In addition, we believe these rules and regulations may make it more difficult and have made it more expensive for us to obtain director and officer liability insurance, and we may be required to accept reduced policy limits and coverage or incur substantially higher costs to obtain the same or similar coverage in the future. As a result, it may be more difficult for us to attract and retain qualified people to serve on our board of directors, our board committees or as executive officers.

Failure to build our finance infrastructure and improve our accounting systems and controls could impair our ability to comply with the financial reporting and internal controls requirements for publicly traded companies.

As a public company, we operate in an increasingly demanding regulatory environment, which requires us to comply with applicable provisions of the Sarbanes-Oxley Act, and the related rules and regulations of the Securities and Exchange Commission, expanded disclosure requirements, accelerated reporting requirements and more complex accounting rules. Company responsibilities required by the Sarbanes-Oxley Act include establishing corporate oversight and adequate internal control over financial reporting and disclosure controls and procedures. Effective internal controls are necessary for us to produce reliable financial reports and are important to help prevent financial fraud. We will need to hire or outsource additional finance personnel and further build our financial infrastructure as a public company, including complying with the applicable requirements of Section 404 of the Sarbanes-Oxley Act. We may be unable to do so on a timely basis. Until we are able to expand our finance and administrative capabilities and establish additional financial reporting infrastructure, we may not be able to prepare and disclose, in a timely manner, our financial statements and other required disclosures or comply with the applicable provisions of the Sarbanes-Oxley Act or existing or new reporting requirements. If we cannot provide reliable financial reports or prevent fraud, our business and results of operations could be harmed and investors could lose confidence in our reported financial information.

Shares eligible for future sale may adversely affect the market for our common stock.

Sales of substantial amounts of our common stock in the public market, or the perception that these sales could occur, could cause the market price of our common stock to decline. These sales could also make it more difficult for us to sell equity or equity-related securities in the future at a time and price that we deem appropriate.

As of March 31, 2015, we had 7,066,137 shares of common stock outstanding. Shares beneficially owned by our affiliates and employees are subject to volume and other restrictions under Rules 144 and 701 under the Securities Act of 1933, as amended, or the Securities Act, various vesting agreements, our insider trading policy and any applicable 10b5-1 trading plan. Shares that are not beneficially owned by our affiliates and employees generally can be freely sold in the public market, subject in some cases to restrictions under Rule 144.

As of March 31, 2015, we also had outstanding options and warrants for the purchase of 1,387,186 shares and 1,564,108 shares, respectively, of our common stock and we may grant additional options and/or warrants in the future. If our stock price rises, the holders of vested options or warrants may exercise their options or warrants and sell a large number of shares. Any sale of a substantial number of shares of our common stock may have a material adverse effect on the market price of our common stock.

Our charter documents and Delaware law may inhibit a takeover that stockholders consider favorable.

Our Certificate of Incorporation, or Certificate, and bylaws and applicable provisions of Delaware law may delay or discourage transactions involving an actual or potential change in control or change in our management, including transactions in which stockholders might otherwise receive a premium for their shares, or transactions that our stockholders might otherwise deem to be in their best interests. The provisions in our Certificate and bylaws:

- authorize our board of directors to issue preferred stock without stockholder approval and to designate the rights, preferences and privileges of each class; if issued, such preferred stock would increase the number of outstanding shares of our capital stock and could include terms that may deter an acquisition of us;
- limit who may call stockholder meetings;
- do not permit stockholders to act by written consent;
- do not provide for cumulative voting rights; and
- provide that all vacancies may be filled by the affirmative vote of a majority of directors then in office, even if less than a quorum.

In addition, Section 203 of the Delaware General Corporation Law may limit our ability to engage in any business combination with a person who beneficially owns 15% or more of our outstanding voting stock unless certain conditions are satisfied. This restriction lasts for a period of three years following the share acquisition. These provisions may have the effect of entrenching our management team and may deprive you of the opportunity to sell your shares to potential acquirers at a premium over prevailing prices. This potential inability to obtain a control premium could reduce the price of our common stock. See “Anti-Takeover Effects of Certain Provisions of Delaware Law and Our Charter Documents” for additional information.

If securities or industry analysts do not publish or do not continue to publish research or reports about our business, or if they issue an adverse or misleading opinion regarding our stock, our stock price and trading volume could decline.

The trading market for our common stock is influenced by the research and reports that industry or securities analysts publish about us or our business. Presently, a limited number of securities analysts publish reports on us on a regular basis. If any of the analysts who cover us now or in the future issue an adverse opinion regarding our stock, our stock price would likely decline. If one or more of these analysts ceases coverage of our company or fail to publish reports on us regularly, we could lose visibility in the financial markets, which in turn could cause our stock price or trading volume to decline.

Risks Related to this Offering

Management will have broad discretion as to the use of the net proceeds from this offering, and we may not use these proceeds effectively.

We have not designated any portion of the net proceeds from this offering to be used for any particular purposes. Our management will have broad discretion in the application of the net proceeds from this offering and could spend the proceeds in ways that do not improve our results of operations or enhance the value of our common stock. Accordingly, you will be relying on the judgment of our management with regard to the use of these net proceeds, and you will not have the opportunity, as part of your investment decision, to assess whether the proceeds are being used appropriately. Our failure to apply these funds effectively could have a material adverse effect on our business, delay the development of our products and cause the price of our common stock to decline.

You will experience immediate and substantial dilution in the net tangible book value per share of the common stock you purchase.

Since the public offering price per share of our common stock is expected to be substantially higher than the net tangible book value per share of our common stock, you will suffer substantial dilution in the net tangible book value of the common stock you purchase in this offering. Our net tangible book value as of March 31, 2015 was approximately \$6.3 million, or approximately \$0.90 per share. After giving effect to the sale of 1,935,500 shares of our common stock in this offering at a public offering price of \$7.75 per share, and after deducting the underwriting discount and estimated offering expenses payable by us, if you purchase shares of our common stock in this offering, you will suffer immediate and substantial dilution of \$5.52 per share in the net tangible book value of the common stock you acquire. See the section titled “Dilution” below for a more detailed discussion of the dilution you would incur if you purchase shares of our common stock in this offering.

In addition, we have a significant number of stock options and warrants outstanding. To the extent that outstanding stock options or warrants have been or may be exercised or other shares issued, you may experience further dilution.

Future sales of substantial amounts of our common stock could adversely affect the market price of our common stock.

We may choose to raise additional capital due to market conditions or strategic considerations even if we believe we have sufficient funds for our current or future operating plans. If additional capital is raised through the sale of equity or convertible debt securities, or perceptions that those sales could occur, the issuance of these securities could result in further dilution to investors purchasing our common stock in this offering or result in downward pressure on the price of our common stock, and our ability to raise capital in the future.

The exercise of outstanding options and warrants to acquire shares of our common stock would cause additional dilution, which could cause the price of our common stock to decline.

In the past, we have issued options and warrants to acquire shares of our common stock. At March 31, 2015, there were 1,387,186 shares of common stock issuable upon exercise of outstanding options at a weighted average exercise price of \$6.51 per share and 1,564,108 shares of common stock issuable upon exercise of outstanding warrants at a weighted average exercise price of \$4.48 per share, and we may issue additional options, warrants and other types of equity in the future as part of stock-based compensation, capital raising transactions, technology licenses, financings, strategic licenses or other strategic transactions. To the extent these options and warrants are ultimately exercised, existing holders of our common stock would experience additional dilution which may cause the price of our common stock to decline.

A large number of shares issued in this offering may be sold in the market following this offering, which may depress the market price of our common stock.

A large number of shares issued in this offering may be sold in the market following this offering, which may depress the market price of our common stock. Sales of a substantial number of shares of our common stock in the public market following this offering could cause the market price of our common stock to decline. If there are more shares of common stock offered for sale than buyers are willing to purchase, then the market price of our common stock may decline to a market price at which buyers are willing to purchase the offered shares of common stock and sellers remain willing to sell the shares. All of the securities issued in the offering will be freely tradable without restriction or further registration under the Securities Act.

USE OF PROCEEDS

We estimate that the net proceeds of this offering will be approximately \$ 13.8 million, \$15.9 million if the underwriters exercise their over-allotment option in full, assuming the sale of 1,935,500 shares of our common stock, 2,225,825 if the underwriters exercise their over-allotment option in full, at a public offering price of \$7.75 per share, after deducting the underwriting discount and estimated offering expenses payable by us.

We intend to use the net proceeds from this offering for working capital and general corporate purposes.

Our management will have broad discretion in the application of the net proceeds from this offering and could spend the proceeds in ways that do not improve our results of operations or enhance the value of our common stock. Accordingly, you will be relying on the judgment of our management with regard to the use of these net proceeds, and you will not have the opportunity, as part of your investment decision, to assess whether the proceeds are being used appropriately. Our failure to apply these funds effectively could have a material adverse effect on our business, delay the development of our products and cause the price of our common stock to decline.

PRICE RANGE OF OUR COMMON STOCK

Our common stock has traded on NASDAQ under the symbol “IPWR” since November 22, 2013. The following table sets forth, for the periods indicated, the high and low intraday sales prices for our common stock as reported by NASDAQ:

	Common Stock Price	
	High	Low
Year Ended December 31, 2013		
Quarter ended December 31, 2013	\$ 5.69	\$ 5.25
Year Ended December 30, 2014		
Quarter ended March 31, 2014	\$ 8.90	\$ 8.00
Quarter ended June 30, 2014	\$ 9.50	\$ 9.09
Quarter ended September 30, 2014	\$ 7.59	\$ 7.34
Quarter ended December 31, 2014	\$ 7.26	\$ 6.99
Year Ended December 31, 2015		
Quarter ended March 31, 2015	\$ 9.71	\$ 9.31

The reported last sale price of our common stock on the NASDAQ on May 12, 2015 was \$9.04 per share. As of May 12, 2015, there were approximately 50 stockholders of record of our common stock.

DIVIDEND POLICY

We have never declared or paid any dividends on our common stock and do not anticipate paying any in the foreseeable future. We currently intend to retain all of our future earnings, if any, to finance the operation and expansion of our business. Any future determination relating to our dividend policy will be made at the discretion of our board of directors and will depend on a number of factors, including future earnings, capital requirements, financial conditions, future prospects, contractual restrictions and covenants and other factors that our board of directors may deem relevant.

CAPITALIZATION

The following table sets forth our cash and cash equivalents and our capitalization as of March 31, 2015:

- on an actual basis; and
- on an as adjusted basis to give effect to the receipt of the estimated net proceeds of approximately \$13.8 million from the sale by us of 1,935,500 shares of our common stock in this offering at a public offering price of \$7.75 per share and after deducting the underwriting discount and estimated offering expenses payable by us. See “Use of Proceeds.”

The offering will not result in an adjustment to our current liabilities.

You should read the data set forth in the table below in conjunction with (i) our consolidated financial statements, including the related notes, and “Management’s Discussion and Analysis of Financial Condition and Results of Operations” from our Annual Report on Form 10-K for the fiscal year ended December 31, 2014, and (ii) our condensed consolidated financial statements, including the related notes, and “Management’s Discussion and Analysis of Financial Condition and Results of Operations” from our Quarterly Report on Form 10-Q for the quarterly period ended March 31, 2015, which are incorporated by reference into this prospectus supplement.

	As of March 31, 2015	
	Actual	As Adjusted ⁽¹⁾
Cash and cash equivalents	\$ 6,169,375	\$ 19,963,033
Stockholders’ equity:		
Common stock, \$0.001 par value; 50,000,000 shares authorized; 7,066,137 issued and outstanding and 9,001,637 shares issued and outstanding as adjusted	7,066	9,002
Additional paid-in capital	33,175,444	46,967,166
Treasury stock	(2,657)	(2,657)
Accumulated deficit	(25,845,429)	(25,845,429)
Total stockholders’ equity	7,334,424	21,128,082
Total capitalization	\$ 7,334,424	\$ 21,128,082

- (1) As adjusted to reflect the sale of 1,935,500 shares of our common stock in this offering at a public offering price of \$7.75 per share and the receipt of the estimated net proceeds from the sale of those shares after deducting the underwriting discount and estimated offering expenses payable by us.

The common stock shown as issued and outstanding in the table above is based on 7,066,137 shares of common stock outstanding as of March 31, 2015, and excludes, as of that date:

- 1,387,186 shares of common stock issuable upon the exercise of outstanding stock options, having a weighted average exercise price of \$6.51 per share;
- 1,564,108 shares of our common stock issuable upon the exercise of outstanding warrants with a weighted-average exercise price of \$4.48 per share; and
- 135,677 shares available for future grant under our 2013 Equity Incentive Plan.

DILUTION

If you purchase shares of our common stock in this offering, you will experience dilution to the extent of the difference between the price per share you pay in this offering and the net tangible book value per share of our common stock immediately after this offering. Our net tangible book value (deficit) on March 31, 2015 was approximately \$6.3 million, or approximately \$0.90 per share. Net tangible book value (deficit) per share is equal to the amount of our total tangible assets, less total liabilities, divided by the aggregate number of shares of common stock outstanding. After giving effect to the sale by us of 1,935,500 shares of our common stock in this offering at a public offering price of \$7.75 per share, and after deducting the underwriting discount and estimated offering expenses payable by us, our as adjusted net tangible book value (deficit) as of March 31, 2015 would have been approximately \$20.1 million, or approximately \$2.23 per share. This represents an immediate increase in net tangible book value of approximately \$1.33 per share to existing stockholders and an immediate dilution of \$5.52 per share to investors purchasing shares of common stock in this offering. The following table illustrates this per share dilution:

Public offering price per share		\$	7.75
Net tangible book value (deficit) per share as of March 31, 2015	\$	6,310,656	
Increase per share attributable to new investors in this offering	\$	<u>1.33</u>	
Net tangible book value (deficit) per share as of March 31, 2015 after giving effect to this offering		\$	<u>2.23</u>
Dilution per share to investors participating in this offering		\$	<u>5.52</u>

If the underwriters exercise in full their option to purchase additional shares, the pro forma as adjusted net tangible book value per share after giving effect to this offering would be \$2.39 per share which, represents an immediate increase in net tangible book value of approximately \$1.49 per share to existing stockholders and an immediate dilution of \$5.36 per share to investors purchasing shares of common stock in this offering and after deducting the underwriting discount and estimated offering expenses payable by us.

The foregoing discussion and table do not take into account further dilution to new investors that could occur upon the exercise of outstanding options and warrants having a per share exercise price less than the public offering price per share in this offering.

The foregoing discussion and table are based on 7,066,137 shares of common stock issued and outstanding as of March 31, 2015 and exclude, as of that date:

- 1,387,186 shares of common stock underlying outstanding options at a weighted average exercise price of \$6.51 per share;
- 1,564,108 shares of common stock underlying outstanding warrants at a weighted average exercise price of \$4.48 per share; and
- 135,677 shares available for future grant under our 2013 Equity Incentive Plan.

In addition, we may choose to raise additional capital due to market conditions or strategic considerations even if we believe that we have sufficient funds for our current or future operating plans. To the extent that additional capital is raised through the sale of equity or convertible debt securities, the issuance of these securities could result in further dilution to our stockholders.

OUR BUSINESS

We design, market and sell electrical power conversion products using our proprietary technology called Power Packet Switching Architecture, or PPSA. Our PPSA technology enables high efficiency power conversion by eliminating many of the heavy, passive components used in conventional power conversion products and replacing them with computing and switching technologies. Our products are designed to be used in both on-grid and off-grid applications. We believe our products are the only transformer-less power converters approved for use in on-grid applications. Our PPSA technology is protected by a patent portfolio of 21 US and four foreign patents. We own all of the rights to our PPSA technology.

We sell our products primarily to systems integrators for installation as part of a larger turn-key system providing the end user with a complete solution for managing their energy consumption. These customers sell systems that enable end users to manage their electricity consumption by reducing demand charges and integrating renewable energy sources. We also sell systems to commercial end users that enable them to reduce fossil fuel consumption, and form their own microgrid. Our products are made by contract manufacturers to our specifications, enabling us to scale production to meet demand on a cost-effective basis without requiring significant expenditures on manufacturing facilities and equipment.

Background

We believe that significant changes in the supply of and demand for electrical power are driving demand for new energy infrastructure products and supporting technologies. Electrical power is generated from central stations and transmitted over long distance high-voltage transmission lines to substations where the voltage is reduced for distribution to consumers. Utility grids are built to manage the flow of power in one direction, from generation to use, where sophisticated tools have been developed to constantly match the amount of power being generated with the amount being consumed. Utilities ramp power plants up or down to closely match generation with load.

The rapid growth in worldwide renewable energy generation, such as wind and solar power, has added a new level of complexity to the equation. These intermittent resources cannot be dispatched at will or relied upon to meet the peak power demands of the grid. Renewable energy sources tend to ramp up and down quickly. For example, a single cloud over a photovoltaic, or PV, farm can cause electrical output to change dramatically in a matter of seconds. These new challenges make it increasingly difficult for utilities to accurately forecast and meet peak power demands.

Increased peak demand for power also has exposed weaknesses in the existing power grid. In high-cost, high-demand states, such as California, public utilities have instituted peak demand charges as a way to ration power during periods of peak demand and to incentivize customers to shift their power consumption to off-peak times. At the same time, both the Federal and state governments have created incentive programs to encourage the development and implementation of alternative energy sources, such as solar and wind power, which has the perverse consequence of making peak demand more difficult to forecast and satisfy. Strains on the electric grid have resulted in significant brown-outs and black-outs that have heightened awareness of the vulnerabilities of the existing system. As a result, power consumers are turning to new technologies to manage their energy consumption, lower costs and assure a reliable source of supply. We believe that distributed power conversion systems, such as our PPSA products, have become an increasingly important element of this new infrastructure.

In response to these changes in the market for electrical power, a number of technologies have been developed to enable users to more effectively manage their consumption. For example, a commercial business can shift energy usage from peak to non-peak times by installing a battery energy storage system, or BESS. The customer can use electricity generated during off-peak hours to charge the BESS and then use the stored power to satisfy all or part of its demand during peak hours. Similarly, an industrial or residential user can install a solar power system to generate power for use either immediately upon generation or for storage in a BESS for later use.

Battery storage systems and many alternative energy sources provide power on a direct current, or DC, basis. However, the electric power grid and most electrical equipment operates on alternating current, or AC. Consequently, power conversion systems are required to convert power from DC to AC or from AC to DC, as necessary to make the various components of the system function together. In addition to converting power, power conversion systems enable customers to regulate current, voltage and frequency, and include balancing system resources to optimize generation. Power converters also manage distributed grid energy storage and can be used to create stand-alone microgrids to bring power to a business or residence should the main electrical grid, if one is present, be unavailable.

BESS systems and alternative energy sources, such as solar or wind power, can only be connected to the existing power grid if they are electrically isolated to prevent power from flowing back into the grid and potentially damaging components of the power system or creating potential safety hazards. Traditionally, heavy, wire-wound transformers have been used to isolate these components from the grid. These conversion systems also use other passive components which make them big, heavy, expensive and inefficient due to the large quantity of copper and magnetic material required. Transformer-less power conversion systems in battery applications nevertheless require the bulky transformers and thus have many of the same drawbacks as transformer-based systems. Consequently, power conversion systems with transformers are relatively large, expensive to manufacture, ship and install and require larger spaces for installation and heat dissipation.

Our PPSA Technology

Our PPSA-based products provide the same electrical isolation as traditional, transformer-based power conversion systems. We believe our products are the only commercial transformer-less power conversion systems that provide the electrical isolation required to connect alternative energy sources and battery storage systems to the grid. Because our products use computing and switching technologies to replace the traditional transformer and other bulky, passive components used in traditional power conversion systems, our power conversion systems are lighter, smaller and more efficient.

Our PPSA technology uses indirect power flow in which power flows through input switches and is temporarily stored in our proprietary AC link inductor. Our proprietary fast switching algorithms enable the transfer of quantum packets of power between ports in our system. As the AC link becomes charged, it disconnects from its input switches, resonates without being connected to either the input or output switches, and then reconnects to its output switches when it reaches the correct voltage and frequency for the application, providing true electrical isolation without the need for a transformer. Figure 1 below illustrates this process.

Figure 1: Schematic of PPSA Process

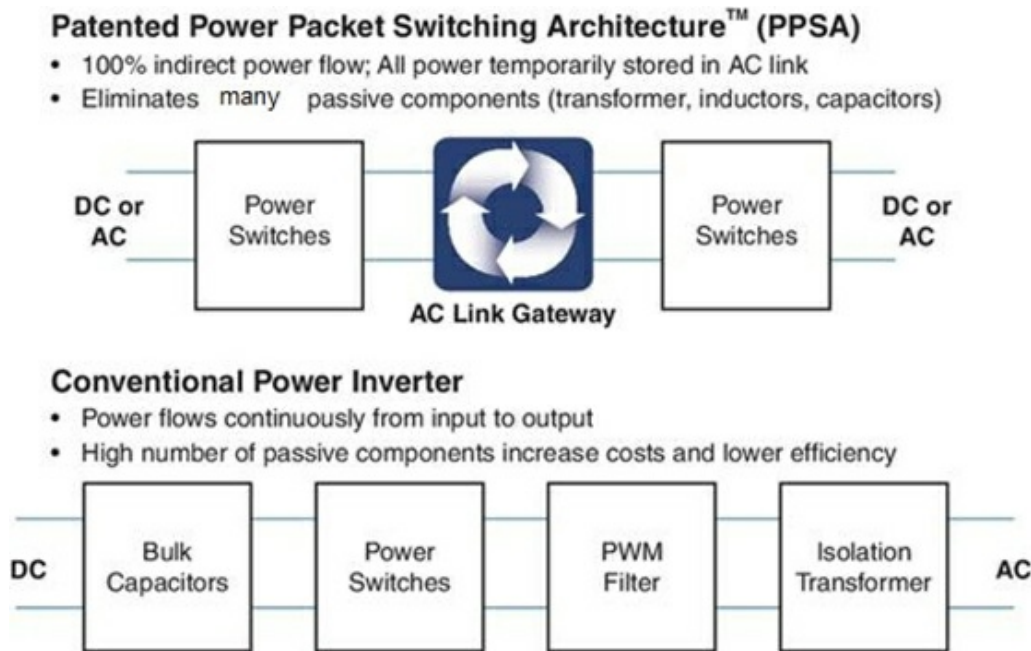

Transformer-based power conversion systems use continuous power flow that relies on relatively heavy and expensive magnetic components and bulk capacitors. Many of these traditional systems have custom hardware for specific functions and are not readily adaptable or customizable. Because they are relatively inefficient, these systems generate excess heat that causes electrical and thermal stresses resulting in drive component failures and losses. By contrast, our conversion technology eliminates the majority of the passive components of traditional power conversion systems, including transformers, inductors and bulk capacitors.

We believe our PPSA technology offers several key advantages over traditional technologies, such as:

- **Size and Weight:** PPSA architecture reduces size and weight by eliminating passive components such as transformers, inductors and bulk capacitors. Our 30kW power conversion system weighs 97 pounds. By contrast, similar transformer-based 30kW power conversion systems weigh over 600 pounds.
- **Efficiency:** Efficiency is the measure of power out of the power conversion system as a percentage of the power into the system. Thus, high efficiency systems use less power in the conversion process and supply more power for use. In the California Energy Commission, or CEC, weighted efficiency test, our 30kW power conversion system scored 96.5%. Our efficiency advantage is more pronounced when operating the system at relatively low rated power, which is more common in battery systems.

Figure 2 illustrates these advantages:



- Cost: Reduced weight results in lower material, transportation and installation costs.
- Safety: Because our systems provide electrical isolation, our systems may be grounded which is safer for the end user. By contrast, non-grounded systems require additional safeguards to pass U.S. safety regulations, which increases system cost and reduces efficiency.
- Scalability/Flexibility: Our products use standardized hardware with application specific software, which we believe gives us the ability to reduce development time for new products and new applications. With our proprietary system architecture, we believe we can design and develop a wide range of products from small commercial-scale (below 10kW) to utility-scale (over 1MW).
- Reliability: Because our systems use fewer passive components and operate at lower temperatures, we believe that our systems are more reliable than traditional power converters.

Existing Products

We have six products based on our PPSA technology currently in production. Each of these products is briefly described below:

- 30kW photovoltaic, or PV, Inverter, which has a UL 1741 certification and is intended to be used for commercial and industrial solar power installations. This is our first product and shares the same hardware as the Company's 30kW battery converter described below but uses embedded software specific to a PV application.
- 30kW Battery Converter, which has a UL 1741 certification and is intended to be used for commercial and industrial grid-tied distributed energy storage market. This battery converter is bi-directional, which means it can distribute power to or from a BESS array. This product uses the same hardware design as the 30kW PV Inverter, but has embedded software that enables bi-directional power conversion and control. This product is more efficient and approximately only 1/5th the size and weight of similar transformer-based products. The 30kW Battery Converter also has a significantly lower acoustic noise profile and can be installed in buildings without the need for acoustic isolation or insulation.
- 30kW grid-resilient AC-DC power conversion system. This product is able to convert to both 50Hz and 60Hz AC current and has the ability to form and manage a microgrid. It is intended for use by customers who are interested in our existing 30kW battery converter but need to use the product overseas or need the additional capability to form a microgrid. This product is not a replacement for our 30kW battery converter but complements the existing product with additional features.
- 30kW grid-resilient AC-DC-DC multi-port power conversion system with two DC ports enabling two DC inputs, such as a PV and a battery storage system, to be installed with one power converter. This product is capable of managing the conversion to both 50Hz and 60Hz AC current, enabling the ability to operate in grids outside of North America. This product also has the ability to form and manage a microgrid, effectively using energy storage with distributed generation resources to support critical loads or allow a building to disconnect from the utility power grid. We expect to receive UL 1741 certification for grid-tied applications of this product in the second quarter 2015. This product received the "Electrical Energy Storage Award" for product innovation at InterSolar, Germany, the world's largest solar exhibition.
- 125kW grid-resilient AC-DC power conversion system, for higher power applications. This 125kW system has over four times the power of the 30kW product and is also able to convert to both 50Hz and 60Hz AC current. This product is primarily for use in grid-tied applications, and we expect to receive its UL 1741 certification in the second half of 2015. It also has the ability to form and manage a microgrid.
- 125kW grid-resilient AC-DC-DC multi-port power conversion system for higher power applications with multi-port capabilities. This 125kW system has over four times the power of the 30kW multi-port product and is also able to convert to both 50Hz and 60Hz AC current. This product has the ability to form and manage a microgrid. Because this product is intended primarily for off-grid and microgrid management applications, we do not intend to seek a UL 1741 certification for this product at this time. This product is

currently in prototype production only with the first customer shipment scheduled for May 2015.

The figure below illustrates this product family:



Strategy

Our strategy is to promote and expand the use of our PPSA technology through product development and product sales, including the licensing of our product designs to systems integrators and other original equipment manufacturers, or OEMs. We intend to target OEMs in the power conversion industry that serve markets and geographies that would be difficult or costly for us to pursue directly and which make complementary products that do not compete with us in our core markets or core product offerings.

Our existing products incorporate multiple IGBTs, which are power switches used in the process to convert power from one current form to another. IGBTs switch power in only one direction (DC to AC or AC to DC) and require the use of a diode to prevent power from flowing back into the system. To enable our existing products to perform bi-directional power conversion, for each IGBT and diode used in our products, we must include a second IGBT and diode. These components result in a slight voltage drop that affects the electrical efficiency of our products and generate excess heat that must be dissipated. Funded in part by a \$2.5 million ARPA-E grant from the U.S. Department of Energy, we are developing a bi-directional IGBT, or BD-IGBT, that we believe will allow us to substitute one BD-IGBT for each pair of IGBTs and diodes used in our current products. Based on our software simulations, we believe that the BD-IGBTs can improve electrical efficiency from approximately 96.5% to greater than 98%, which would reduce the heat generated by the operation of our products. As a result, products incorporating BD-IGBTs will require less space for heat dissipation which would allow us to reduce our material costs. We believe that these development efforts, if successful, will enhance the competitive position of our products.

Figure 4 illustrates the potential benefits of our BD-IGBT Power Switch Components, which are under development. Estimates below are based upon our software simulations:

	Current Technology	BD-IGBT
IGBT	standard	bi-directional
Power	30kW	60kW
Weight	97lbs	~100lbs
Power Density	309W/lb	>550W/lb
Efficiency (CEC)	96.5%	>98%

We expect that our intellectual property rights will continue to be a significant asset to us and our strategy is to actively pursue patent protection for our innovative technologies in the U.S. and other commercially important global markets. We have 21 issued U.S. patents and four issued foreign patents. We have filed numerous additional pending U.S., foreign and international patent applications.

Target Markets

We have focused our sales and marketing efforts on markets where we believe our technology has the most value. We focus on sales to commercial and industrial customers in which there is a need for power conversion systems to:

- manage consumption to reduce peak power demands;
- integrate new sources of generation such as distributed PV; and
- form microgrids.

We believe our products provide compelling advantages to commercial or industrial customer having these needs due to the reduced weight, compact size, quiet operation, high efficiency and reliability, and advanced programmability of our products compared to traditional power conversion systems.

According to Yole Development, or Yole, a global research firm specializing in the scientific and power electronics markets, the global power conversion market was approximately \$50 billion in 2014 and is forecast to grow to over \$70 billion by 2020. Yole estimates that the highest rate of growth will be in the battery and microgrid power conversion market, which they forecast to grow 40% annually over this period.

Battery and Microgrid Power Conversion Market

BESS systems are battery arrays coupled with a power conversion system to enable electric power to be captured, stored, and used on an electric power grid. These systems can be large, megawatt-scale systems operated by utilities to better manage their system resources, or small, kilowatt-scale systems in homes and businesses designed to enable consumers to manage their power use and mitigate utility imposed demand charges. In certain U.S. markets, such as California, New York, and Massachusetts, there are economic incentives available to commercial and industrial consumers in the form of reduced demand charges for installing a BESS system and reducing peak consumption. There is also emerging regulatory policy that is driving the adoption of energy storage. For example, California has issued a mandate for over 1,000 megawatts of new energy storage to be installed by 2020, and currently offers attractive rebates to end users who install a BESS through its Self-Generation Incentive Program. Our 30kW and 125kW AC-DC power conversion systems enable these BESS systems to connect to the utility grid.

Typically, PV systems are connected to the utility power grid so customers can continue to receive power from the utility to augment their PV systems and, in some cases, to sell power back to the utility. As a result, when the utility power grid becomes unavailable or experiences a blackout, the PV system is prevented by design from generating power to avoid damaging grid equipment or creating a safety hazard. Our grid-resilient multi-port power conversion systems are designed to address this problem by enabling a solar PV system with a BESS to operate and be managed as a local microgrid even when the utility grid is down. In addition, our grid-resilient multi-port power conversion systems work with other energy sources, such as a diesel generator coupled with a BESS system.

We sell a number of our products to commercial BESS integrators, such as Sharp Electronics, Green Charge Networks, EOS Energy Storage, and CODA Energy.

Commercial and industrial BESS systems are used for more than peak demand reduction. IHS, a global research firm, forecasts that global installations of grid-tied commercial BESS systems coupled with PV, a subset of the battery and microgrid market, will grow 111% annually to over 600 MW of BESS systems by 2018. IHS predicts that that this growth will occur through new systems deployed in two principle configurations:

- The current method of using a separate BESS and PV system tied together through the AC wiring; and
- The emerging use of a BESS and the PV system behind a single power conversion system with two DC inputs in a microgrid configuration.

Our existing products can address each of these configurations.

We believe these new systems will be used to:

- provide backup power during blackouts;
- improve grid stability in high penetration PV areas; and
- reduce diesel fuel consumption in remote off-grid microgrids.

Other Microgrid Applications

We believe, based on our analysis of market characteristics including existing grid infrastructure, high diesel fuel costs, good solar irradiance, and projected population growth, regions such as Southeast Asia, Africa, the Middle East, and Central and South America will have increasing demand for new power generation capacity. Remote communities with limited infrastructure in these regions depend more on expensive diesel fuel to generate electricity and may not have a utility power grid for access to high quality, reliable power. As a result, we believe that these less developed countries represent a significant opportunity for our grid-resilient products. IHS has predicted that the market for off-grid and microgrid BESS installations with PV will reach 400MW by 2018 with the majority of this growth coming from regions with less developed electricity infrastructure.

In September 2014, we entered into a strategic partnership with EnerDel Inc., which is developing a new line of Mobile Hybrid Power Systems, or MHPS, that integrate our Grid-Resilient 30kW Multi-Port Power Conversion System, a diesel generator, and EnerDel Inc.'s lithium-ion batteries and proprietary control system. This new MHPS is designed for both remote and grid-tied microgrid applications that depend on diesel generators as the primary power source.

Other Markets

In addition to the markets discussed above, we believe there are other potential market opportunities for our power conversion systems. As an example, we have provided power conversion systems to NRG Energy, Inc. for a California Public Utility Commission-approved technology demonstration program to reduce the installation and operational costs of DC charging infrastructure for electric vehicles and, in September 2014, NRG purchased two of our 30kW battery converters for installation at a demonstration site at the University of California San Diego. Additionally, we shipped our first order for the commercial wind turbine market in September 2014. We believe our PPSA technology can also be used in other verticals within the global power conversion market.

Intellectual Property

We rely on a combination of patents, laws that protect intellectual property, confidentiality procedures, and contractual restrictions with our employees and others, to establish and protect our intellectual property rights. In addition, the software that is shipped with our products is encrypted.

We have 21 issued U.S. patents and four issued foreign patents. We have a number of additional pending U.S., foreign and international patent applications. We expect to continue to build our patent estate for both our core power conversion technology and other technological developments that broaden the scope of our technology platform. The issue date and expiration date of our issued U.S. and foreign patents is included in the table below:

Title	Number	Issued	Expires (Estimate)
Universal Power Converter	7,599,196	6-Oct-09	6-Oct-2028
Universal Power Converter Methods	7,778,045	17-Aug-10	5-Jun-2029
Power Conversion with Added Pseudo-Phase Converter For Enhanced Efficiency Power Conversion	8,295,069	23-Oct-12	17-Aug-2030
Universal Power Converter with Bidirectional Switching Devices	8,300,426	30-Oct-12	30-Mar-2028
Power Transfer Devices, Methods, and Systems with Crowbar Switch Shunting Energy-Transfer Reactance	8,345,452	1-Jan-13	6-Jun-2027
Buck-Boost Power Converter Circuits, Methods and Systems	8,391,033	5-Mar-13	29-Jun-2030
Universal Power Converter with Two Input Drive Operations During Each Half-Cycle Power Conversion with Added Pseudo-Phase	8,395,910	12-Mar-13	6-Jun-2027
Power Transfer Devices, Methods, and Systems with Crowbar Switch Shunting Energy-Transfer Reactance	8,400,800	19-Mar-13	6-Jun-2027
Power Transfer Devices, Methods, and Systems with Crowbar Switch Shunting Energy-Transfer Reactance	8,406,025	26-Mar-13	17-Aug-2030
Power Transfer Devices, Methods, and Systems with Crowbar Switch Shunting Energy-Transfer Reactance	8,432,711	30-Apr-13	29-Jun-2030
PV Array Systems, Methods, and Devices with Improved Diagnostics and Monitoring	8,441,819	14-May-13	29-Jun-2030
PV Array Systems, Methods, and Devices with Improved Diagnostics and Monitoring	8,446,042	21-May-13	30-Nov-2031
Power Transfer Devices, Methods, and Systems with Crowbar Switch Shunting Energy-Transfer Reactance	8,446,043	21-May-13	30-Nov-2031
Power Transfer Devices, Methods, and Systems with Crowbar Switch Shunting Energy-Transfer Reactance	8,446,705	21-May-13	29-Jun-2030
Photovoltaic Array Systems, Methods, and Devices with Bidirectional Converter	8,451,637	28-May-13	29-Jun-2030
Photovoltaic Array Systems, Methods, and Devices with Bidirectional Converter	8,461,718	11-Jun-13	30-Nov-2031
Power Conversion with Added Pseudo-Phase	8,471,408	25-Jun-13	30-Nov-2031
Power Conversion with Current Sensing Coupled through Saturating Element	8,514,601	20-Aug-13	17-Aug-2030
Power Conversion with Current Sensing Coupled through Saturating Element	8,531,858	10-Sep-13	20-Feb-2032
Systems, Circuits, Devices, and Methods with Bidirectional Bipolar Transistors	9,007,796	14-Apr-15	20-Feb-2032
Universal Power Converter	9,029,909	12-May-15	24-Jun-2034
Photovoltaic Array Systems, Methods, and Devices with Bidirectional Converter	CN101523710B	5-Mar-14	6-Jun-2027
Universal Power Converter	SG190401	28-May-14	30-Nov-2031
Power Converter with Added Pseudo-Phase	EP2025051	31-Dec-14	6-Jun-2027
	CA2808490	3-Feb-15	17-Aug-2030

On October 4, 2013 we received a letter from a competitor alleging that the system architecture described on our website appears to infringe on patents licensed to or held by the competitor. The letter asked that we explain why we believe that our technology does not represent an infringement. This competitor sent a subsequent letter on February 3, 2014 directly alleging our PPSA technology infringed the competitor's patent. Following receipt of the first letter, we investigated the competitor's claims and determined that their allegations were without merit. In early 2014, following our receipt of the February 3, 2014 letter, we met with the competitor to discuss their claims. No resolution regarding the competitor's claims has been reached. No subsequent discussions have been held with, and no further correspondence has been received from, this competitor.

Development Relationships

We have entered into a number of licensing and development arrangements for our PPSA technology in both the private and public sectors.

We received an award of \$2.5 million from ARPA-E for the development of our BD- IGBT technology. Funds under the award have been spent and continuing development work is being self-funded. We expect results from our initial hardware tests in the second half of 2015.

In May 2013, we announced a Cooperative Research and Development Agreement with the National Renewable Energy Laboratory. Under this agreement, the National Renewable Energy Laboratory used our technology to develop and test next generation electric vehicle DC charging infrastructure solutions. In connection with The goal of this effort was to create standard reference designs using our PPSA technology in the 3-port hybrid converter that can readily be adopted by commercial and municipal electronic vehicle fleets, military installations, and public infrastructure. These reference designs sought to improve the cost, efficiency and reliability of power conversion, as well as provide grid energy storage and emergency backup power capabilities. This project is complete.

Customers

Because we have only recently commenced commercial sales of our products, a small number of customers have accounted for a substantial amount of our revenue. One customer, the Department of Energy, from which the Company received \$579,079 in grant revenues in 2014, accounted for 32% of net revenue for the year ended December 31, 2014 while our three largest customers for product sales, from whom we received \$789,000 in product revenues in 2014, accounted for 20%, 13% and 11% of net revenues in 2014. One customer, the Department of Energy, from which we received \$1,229,036 in net revenues in 2013, accounted for 65% of net revenue for the year ended December 31, 2013. No customers for product sales represented 10% or more of our net revenues in 2013.

Sales and Marketing

We sell our products primarily to systems integrators for installation as part of a larger turn-key system providing the end user with a complete solution for managing their energy consumption. Our products are sold by us directly to customers and are also marketed through a distribution channel partner. Before a system integrator agrees to specify our products in their systems, the integrator engages in a lengthy and time-consuming process of testing and evaluating our equipment for use, which can take from six months to over a year.

For certain geographic markets and applications, we may seek to enter into licensing agreements with larger organizations that would enable manufacturers to build our products under license for sale in local markets, or we may license product designs to global brands for specific applications.

Manufacturing and Supply

We use a contract manufacturer to manufacture our products to our specifications. We have an agreement with our manufacturer pursuant to which we provide them with a rolling forecast of our expected demand. Finished products are produced based on upon our forecast, and we have the ability to delay shipments for up to 18 months. This agreement renews annually in October 2017 unless terminated. We believe there are several manufacturers that are qualified to manufacture our products to our specifications.

Typically, our manufacturer is responsible for the sourcing of components and materials. We qualify sources for our components and materials. Our strategy is to have multiple suppliers for all of our components and materials. Currently, we have multiple sources for most of our component, although some are singled sourced.

Backlog

The Company's backlog of released and firm orders was approximately \$1.9 million at March 31, 2015. We did not have backlog at March 31, 2014. The Company defines backlog as consisting of accepted orders from customers for which a product delivery schedule has been specified. The purchased orders comprising backlog are not cancellable in most cases and such orders do not provide price protection. Nevertheless, deliveries against received purchase orders may be rescheduled or cancelled with our consent, and our backlog may therefore not be indicative of the level of future sales.

Competition

We compete with a number of providers of power conversion technology, nearly all of whom have greater financial, development and marketing resources than we do. We believe the principal competitive factors in the markets in which we compete are efficiency, reliability, capability, cost and weight. We believe that our PPSA products compete favorably on each of these factors.

Our products compete with transformer-based power conversion systems, which have dominated the power conversion market due to their proven technology and long history of use. However, transformer-based systems are less efficient, heavier, bulkier and more expensive than our products. Major suppliers in this market include ASEA Brown Boveri, Ltd., Eaton Corporation plc, and Schneider Electric SE.

Transformer-less PV solar inverters are a special class of power conversion system applicable only to PV arrays. These transformer-less inverters are one-way (DC to AC) inverters, and provide no electrical isolation as PV systems are not required to be electrically isolated in most electrical code jurisdictions. Because these inverters are not electrically isolated, they cannot be connected to existing power grids. Providers of transformer-less PV inverters include companies such as SMA Solar Technology AG and KACO new energy, Inc.

Research and Development Costs

During the years ended December 31, 2014 and December 31, 2013, we incurred \$2,901,890 and \$2,643,096, respectively, in research and development costs, of which \$643,421 and \$1,430,798, respectively, were included in cost of revenues and \$2,258,469 and \$1,212,298, respectively, were included in operating expenses.

Employees

As of February 28, 2015, we had 22 full-time employees. None of these employees are covered by a collective bargaining agreement, and we believe our relationship with our employees is good.

Industry Certifications

Industry certifications are generally required for products intended to be connected to the existing power grid. The main certification requirement is UL 1741, which tests and guarantees grid safety and product safety for distributed generation sources including PV inverters, battery converters, and bi-directional EV chargers. A National Recognized Testing Laboratory, or NRTL, must complete the certification before our customers may install and use our products in most applications in the United States.

Europe and Japan have different certification test procedures, but generally test for similar capabilities. Certifications are likely to be required to sell our products in these regions. Geographic regions outside of North America, Europe and Japan generally do not have specific certification requirements, but may require one or more of the other regional certifications before products are approved for sale.

Government Regulation

Government approval is not required for us to sell our products. However government support for renewable energy, grid storage, electric vehicle charging infrastructure and improved grid resiliency may impact growing markets that we service. Utility regulations and support may also impact these end markets. Government and utility support for these markets is generally required near term for these markets to grow and changes in policy by governments or utilities may limit the market opportunities for our products.

UNDERWRITING

We have entered into an underwriting agreement with Roth Capital Partners, LLC, acting as the representative of the several underwriters named below, with respect to the shares of our common stock subject to this offering. Subject to certain conditions, we have agreed to sell to the underwriters, and the underwriters have severally agreed to purchase, the number of shares of common stock provided below opposite their respective names.

Underwriters	Number of Shares
Roth Capital Partners, LLC	1,451,625
National Securities Corporation	290,325
Northland Securities, Inc.	193,550
Total	1,935,500

The underwriters are offering the shares of our common stock subject to their acceptance of the shares of our common stock from us and subject to prior sale. The underwriting agreement provides that the obligations of the several underwriters to pay for and accept delivery of the shares of common stock offered by this prospectus supplement and the accompanying prospectus are subject to the approval of certain legal matters by their counsel and to certain other conditions. The underwriters are obligated to take and pay for all of the shares of common stock if any such shares are taken. However, the underwriters are not required to take or pay for the shares of our common stock covered by the underwriters' over-allotment option described below.

Over-Allotment Option

We have granted the underwriters an option, exercisable for 30 days from the date of this prospectus supplement, to purchase up to an aggregate of 290,325 additional shares of our common stock to cover over-allotments, if any, at the public offering price set forth on the cover page of this prospectus supplement, less the underwriting discount. The underwriters may exercise this option solely for the purpose of covering over-allotments, if any, made in connection with the offering of the shares of our common stock offered by this prospectus supplement and the accompanying prospectus. If the underwriters exercise this option, each underwriter will be obligated, subject to certain conditions, to purchase a number of additional shares proportionate to that underwriter's initial purchase commitment as indicated in the table above for which the option has been exercised.

Discount, Commissions and Expenses

The underwriters have advised us that they propose to offer the shares of our common stock to the public at the public offering price set forth on the cover page of this prospectus supplement and to certain dealers at that price less a concession not in excess of \$0.465 per share. The underwriters may allow a discount from the concession not in excess of \$0.465 per share to certain brokers and dealers. After this offering, the public offering price and concession to dealers may be changed by the representative. No such change shall change the amount of proceeds to be received by us as set forth on the cover page of this prospectus supplement. The shares of our common stock are offered by the underwriters as stated herein, subject to receipt and acceptance by them and subject to their right to reject any order in whole or in part. The underwriters have informed us that they do not intend to confirm sales to any accounts over which they exercise discretionary authority.

The following table shows the underwriting discount payable to the underwriters by us in connection with this offering. Such amounts are shown assuming both no exercise and full exercise of the underwriters' over-allotment option to purchase additional shares.

	Per Share	Total Without Exercise of Over- Allotment Option	Total With Exercise of Over- Allotment Option
Public offering price	\$ 7.750	\$ 15,000,125	\$ 17,250,144
Underwriting discount	\$ 0.465	\$ 900,008	\$ 1,035,009

We estimate that expenses payable by us in connection with this offering, other than the underwriting discount referred to above, will be approximately \$306,460. We have agreed to reimburse the underwriters for certain out-of-pocket expenses not to exceed \$100,000 in the aggregate. In no event will the total compensation payable to the underwriters and any other member of the Financial Industry Regulatory Authority, Inc. or independent broker-dealer (including any financial advisor) in connection with the sale of the common stock offered hereby exceed 8.0% of the gross proceeds of this offering.

Indemnification

We have agreed to indemnify the underwriters against certain liabilities, including liabilities under the Securities Act of 1933, as amended, or the Securities Act, and liabilities arising from breaches of representations and warranties contained in the underwriting agreement, or to contribute to payments that the underwriters may be required to make in respect of those liabilities.

Lock-up Agreements

We and our officers and directors have agreed, subject to limited exceptions, for a period of 90 days after the date of this prospectus supplement, not to offer, sell, contract to sell, pledge, grant any option to purchase, make any short sale or otherwise dispose of, directly or indirectly any shares of common stock or any securities convertible into or exchangeable for our common stock either owned as of the date of the underwriting agreement or thereafter acquired without the prior written consent of the representative. The representative may, in its sole discretion and at any time or from time to time before the termination of the lock-up period, without notice, release all or any portion of the securities subject to lock-up agreements.

Price Stabilization, Short Positions and Penalty Bids

In connection with the offering the underwriters may engage in stabilizing transactions, over-allotment transactions, syndicate covering transactions and penalty bids in accordance with Regulation M under the Exchange Act:

- Stabilizing transactions permit bids to purchase the underlying security so long as the stabilizing bids do not exceed a specified maximum.
- Over-allotment involves sales by the underwriters of shares in excess of the number of shares the underwriters are obligated to purchase, which creates a syndicate short position. The short position may be either a covered short position or a naked short position. In a covered short position, the number of shares over-allotted by the underwriters is not greater than the number of shares that they may purchase in the over-allotment option. In a naked short position, the number of shares involved is greater than the number of shares in the over-allotment option. The underwriters may close out any covered short position by either exercising their over-allotment option and/or purchasing shares in the open market.
- Syndicate covering transactions involve purchases of shares of the common stock in the open market after the distribution has been completed in order to cover syndicate short positions. In determining the source of shares to close out the short position, the underwriters will consider, among other things, the price of shares available for purchase in the open market as compared to the price at which it may purchase shares through the over-allotment option. If the underwriters sell more shares than could be covered by the over-allotment option, a naked short position, the position can only be closed out by buying shares in the open market. A naked short position is more likely to be created if the underwriters are concerned that there could be downward pressure on the price of the shares in the open market after pricing that could adversely affect investors who purchase in the offering.
- Penalty bids permit the representative to reclaim a selling concession from a syndicate member when the common stock originally sold by the syndicate member is purchased in a stabilizing or syndicate covering transaction to cover syndicate short positions.

These stabilizing transactions, syndicate covering transactions and penalty bids may have the effect of raising or maintaining the market price of our common stock or preventing or retarding a decline in the market price of the common stock. As a result, the price of our common stock may be higher than the price that might otherwise exist in the open market. Neither we nor the underwriters make any representation or prediction as to the direction or magnitude of any effect that the transactions described above may have on the price of the common stock. In addition, neither we nor the underwriters make any representations that the underwriters will engage in these stabilizing transactions or that any transaction, once commenced, will not be discontinued without notice.

Passive Market Making

In connection with this offering, the underwriters and any selling group members may engage in passive market making transactions in our common stock on The NASDAQ Stock Market in accordance with Rule 103 of Regulation M under the Securities Exchange Act of 1934, as amended, during a period before the commencement of offers or sales of common stock and extending through the completion of the distribution. A passive market maker must display its bid at a price not in excess of the highest independent bid of that security. However, if all independent bids are lowered below the passive market maker's bid, that bid must then be lowered when specified purchase limits are exceeded.

Listing and Transfer Agent

Our common stock is listed on NASDAQ and trades under the symbol "IPWR." The transfer agent of our common stock is Corporate Stock Transfer.

Electronic Distribution

This prospectus supplement and the accompanying prospectus in electronic format may be made available on websites or through other online services maintained by one or more of the underwriters, or by their affiliates. Other than this prospectus supplement and the accompanying prospectus in electronic format, the information on any underwriter's website and any information contained in any other website maintained by an underwriter is not part of this prospectus supplement, the accompanying prospectus or the registration statement of which this prospectus supplement and the accompanying prospectus form a part, has not been approved and/or endorsed by us or any underwriter in its capacity as underwriter, and should not be relied upon by investors.

Other

From time to time, certain of the underwriters and/or their affiliates have provided, and may in the future provide, various investment banking and other financial services for us for which services they have received and, may in the future receive, customary fees. In the course of their businesses, the underwriters and their affiliates may actively trade our securities or loans for their own account or for the accounts of customers, and, accordingly, the underwriters and their affiliates may at any time hold long or short positions in such securities or loans. Except for services provided in connection with this offering, no underwriter has provided any investment banking or other financial services to us during the 180-day period preceding the date of this prospectus supplement and we do not expect to retain any underwriter to perform any investment banking or other financial services for at least 90 days after the date of this prospectus supplement.

As of May 8, 2015, one employee of Northland Securities, Inc. owned 1,650 shares of our common stock.

NOTICE TO INVESTORS

Notice to Investors in the United Kingdom

In relation to each Member State of the European Economic Area which has implemented the Prospectus Directive, each, a Relevant Member State, an offer to the public of any securities which are the subject of the offering contemplated by this prospectus supplement and the accompanying prospectus may not be made in that Relevant Member State except that an offer to the public in that Relevant Member State of any such securities may be made at any time under the following exemptions under the Prospectus Directive, if they have been implemented in that Relevant Member State:

- (a) to legal entities which are authorized or regulated to operate in the financial markets or, if not so authorized or regulated, whose corporate purpose is solely to invest in securities;
- (b) to any legal entity which has two or more of (1) an average of at least 250 employees during the last financial year; (2) a total balance sheet of more than €43,000,000 and (3) an annual net turnover of more than €50,000,000, as shown in its last annual or consolidated accounts;
- (c) by the underwriter to fewer than 100 natural or legal persons (other than qualified investors as defined in the Prospectus Directive); or
- (d) in any other circumstances falling within Article 3(2) of the Prospectus Directive, provided that no such offer of these securities shall result in a requirement for the publication by the issuer or the underwriter of a prospectus pursuant to Article 3 of the Prospectus Directive.

For the purposes of this provision, the expression an "offer to the public" in relation to any of the securities in any Relevant Member State means the communication in any form and by any means of sufficient information on the terms of the offer and any such securities to be offered so as to enable an investor to decide to purchase any such securities, as the same may be varied in that Member State by any measure implementing the Prospectus Directive in that Member State and the expression "Prospectus Directive" means Directive 2003/71/EC and includes any relevant implementing measure in each Relevant Member State.

Each underwriter has represented, warranted and agreed that:

- (a) it has only communicated or caused to be communicated and will only communicate or cause to be communicated any invitation or inducement to engage in investment activity (within the meaning of section 21 of the Financial Services and Markets Act 2000 (the FSMA)) received by it in connection with the issue or sale of any of the securities in circumstances in which section 21(1) of the FSMA does not apply to the issuer; and

(b) it has complied with and will comply with all applicable provisions of the FSMA with respect to anything done by it in relation to the securities in, from or otherwise involving the United Kingdom.

European Economic Area

In particular, this document does not constitute an approved prospectus in accordance with European Commission's Regulation on Prospectuses no. 809/2004 and no such prospectus is to be prepared and approved in connection with this offering. Accordingly, in relation to each Member State of the European Economic Area which has implemented the Prospectus Directive (being the Directive of the European Parliament and of the Council 2003/71/EC and including any relevant implementing measure in each Relevant Member State) (each, a Relevant Member State), with effect from and including the date on which the Prospectus Directive is implemented in that Relevant Member State (the Relevant Implementation Date) an offer of securities to the public may not be made in that Relevant Member State prior to the publication of a prospectus in relation to such securities which has been approved by the competent authority in that Relevant Member State or, where appropriate, approved in another Relevant Member State and notified to the competent authority in that Relevant Member State, all in accordance with the Prospectus Directive, except that it may, with effect from and including the Relevant Implementation Date, make an offer of securities to the public in that Relevant Member State at any time:

- to legal entities which are authorized or regulated to operate in the financial markets or, if not so authorized or regulated, whose corporate purpose is solely to invest in securities;
- to any legal entity which has two or more of (1) an average of at least 250 employees during the last financial year; (2) a total balance sheet of more than €43,000,000; and (3) an annual net turnover of more than €50,000,000, as shown in the last annual or consolidated accounts; or
- in any other circumstances which do not require the publication by the Issuer of a prospectus pursuant to Article 3 of the Prospectus Directive.

For the purposes of this provision, the expression an "offer of securities to the public" in relation to any of the securities in any Relevant Member State means the communication in any form and by any means of sufficient information on the terms of the offer and the securities to be offered so as to enable an investor to decide to purchase or subscribe for the securities, as the same may be varied in that Member State by any measure implementing the Prospectus Directive in that Member State. For these purposes the shares of our common stock offered hereby are "securities."

LEGAL MATTERS

The validity of the securities offered hereby will be passed upon for us by DLA Piper LLP (US), Austin, Texas. Lowenstein Sandler LLP, New York, New York is representing the underwriters in connection with this offering.

EXPERTS

Our consolidated financial statements as of December 31, 2014 and 2013, and for each of the years ended December 31, 2014 and 2013, have been incorporated by reference herein and in the registration statement in reliance upon the reports of Gumbiner Savett Inc., independent registered public accounting firm, incorporated by reference herein, and upon the authority of said firm as experts in accounting and auditing.

WHERE YOU CAN FIND ADDITIONAL INFORMATION

We file annual, quarterly and current reports, proxy statements and other information with the SEC. You may read and copy any reports, statements and other information filed by us at the SEC's Public Reference Room at 100 F Street, N.E., Washington, D.C. 20549. Please call (800) SEC-0330 for further information on the Public Reference Room. The SEC maintains an Internet website that contains reports, proxy and information statements and other information regarding issuers, including us, that file electronically with the SEC. The address for the SEC's website is <http://www.sec.gov>.

We make available, free of charge, through our investor relations website, our Annual Reports on Form 10-K, Quarterly Reports on Form 10-Q, Current Reports on Form 8-K, statements of changes in beneficial ownership of securities and amendments to those reports and statements as soon as reasonably practicable after they are filed with the SEC. The address for our website is www.idealpower.com. The contents on our website are not part of this prospectus, and the reference to our website does not constitute incorporation by reference into this prospectus of the information contained at that site.

INCORPORATION OF CERTAIN INFORMATION BY REFERENCE

The SEC allows us to incorporate by reference the information we file with it, which means that we can disclose important information to you by referring you to another document that we have filed separately with the SEC. You should read the information incorporated by reference because it is an important part of this prospectus supplement. We incorporate by reference the following information or documents that we have filed with the SEC (excluding those portions of any Form 8-K that are not deemed "filed" pursuant to the General Instructions of Form 8-K):

- our Annual Report on Form 10-K for the year ended December 31, 2014, filed with the SEC on March 25, 2015;
- our Quarterly Report on Form 10-Q filed with the SEC on May 6, 2015;
- our Current Reports on Form 8-K filed with the SEC on January 12, 2015, February 12, 2015, May 4, 2015 and May 15, 2015; and
- the description of our common stock set forth in the prospectus filed pursuant to Rule 424(b)(3) on November 27, 2013, including any amendments or reports filed for the purpose of updating such description, as supplemented by the “Description of Capital Stock” found on page 7 of the accompanying prospectus.

All reports and other documents we subsequently file pursuant to Section 13(a), 13(c), 14 or 15(d) of the Exchange Act prior to the termination of this offering, including all such documents we may file with the SEC after the date hereof and prior to termination of this offering, but excluding any information furnished to, rather than filed with, the SEC, will also be incorporated by reference into this prospectus supplement and deemed to be part of this prospectus supplement from the date of the filing of such reports and documents.

Any statement contained in any document incorporated by reference herein will be deemed to be modified or superseded for purposes of this prospectus supplement to the extent that a statement contained in this prospectus supplement or any additional prospectus supplements modifies or supersedes such statement. Any statement so modified or superseded will not be deemed, except as so modified or superseded, to constitute a part of this prospectus supplement.

As explained above in “Where You Can Find More Information,” these incorporated documents (as well as other documents filed by us under the Exchange Act) are available at the SEC and may be accessed in a number of ways, including online via the Internet.

We will provide without charge to each person, including any beneficial owner, to whom this prospectus is delivered, upon his or her written or oral request, a copy of any or all documents referred to above which have been or may be incorporated by reference into this supplemental prospectus excluding exhibits to those documents unless they are specifically incorporated by reference into those documents. Written or telephone requests should be directed to:

Ideal Power Inc.
4120 Freidrich Lane, Suite 100
Austin, TX 78744
Attn.: Chief Executive Officer
Tel: (512) 264-1542

We also maintain a web site at www.idealpower.com. The information on our website is not considered a part of, or incorporated by reference in, this prospectus or any other document we file with or furnish to the SEC.

The information in this prospectus is not complete and may be changed. We may not sell these securities or accept an offer to buy these securities until the Securities and Exchange Commission declares our registration statement effective. This prospectus is not an offer to sell these securities and is not soliciting an offer to buy these securities in any state where the offer or sale is not permitted.

The information in this prospectus is not complete and may be changed. We may not sell these securities or accept an offer to buy these securities until the Securities and Exchange Commission declares our registration statement effective. This prospectus is not an offer to sell these securities and is not soliciting an offer to buy these securities in any state where the offer or sale is not permitted.

SUBJECT TO COMPLETION, DATED DECEMBER 1, 2014



PROSPECTUS

IDEAL POWER INC.

\$75,000,000

Common Stock

Preferred Stock

Warrants

We may offer and sell, from time to time in one or more offerings, any combination of securities that we describe in this prospectus having an aggregate initial offering price of up to \$75,000,000. We may also offer common stock or preferred stock upon exercise of warrants; and common stock upon conversion of preferred stock or any combination thereof.

We will provide specific terms of these offerings and securities in one or more supplements to this prospectus. We may also authorize one or more free writing prospectuses to be provided to you in connection with these offerings. The accompanying prospectus supplement, and any documents incorporated by reference, may also add, update or change information contained in this prospectus. You should read this prospectus, the accompanying prospectus supplement, any documents incorporated by reference and any related free writing prospectus carefully before buying any of the securities being offered.

Our common stock is traded on The NASDAQ Capital Market under the symbol "IPWR." On November 25, 2014, the last reported sale price of our common stock on The NASDAQ Capital Market was \$7.32. The applicable prospectus supplement will contain information, where applicable, as to any listing, if any, on The NASDAQ Capital Market or any other securities market or other exchange covered by the applicable prospectus supplement.

The shares of common stock offered by us may be sold directly by us, through dealers or agents designated from time to time, to or through underwriters or dealers or through a combination of these methods on a continuous or delayed basis. See "Plan of Distribution" in this prospectus. We may also describe the plan of distribution for any particular offering of our securities in a prospectus supplement. If any agents, underwriters or dealers are involved in the sale of any securities in respect of which this prospectus is being delivered, we will disclose their names and the nature of our arrangements with them in a prospectus supplement. The net proceeds we expect to receive from any such sale will also be included in a prospectus supplement.

Investing in our securities involves various risks. See "Risk Factors" beginning on page 3 of this prospectus and the risks set forth under the caption "Item 1A. Risk Factors" included in our most recent Annual Report on Form 10-K and Quarterly Reports on Form 10-Q. Additional risks will be described in the related prospectus supplements under the heading "Risk Factors". You should review that section of the related prospectus supplements for a discussion of matters that investors in our securities should consider.

Neither the Securities and Exchange Commission nor any state securities commission has approved or disapproved of these securities, or passed upon the adequacy or accuracy of this prospectus or any accompanying prospectus supplement. Any representation to the contrary is a criminal offense.

The date of this prospectus is December 1, 2014

TABLE OF CONTENTS

	Page
<u>ABOUT THIS PROSPECTUS</u>	2
<u>OUR BUSINESS</u>	2
<u>RISK FACTORS</u>	4
<u>DISCLOSURE REGARDING FORWARD-LOOKING STATEMENTS</u>	4
<u>USE OF PROCEEDS</u>	4
<u>THE SECURITIES WE MAY OFFER</u>	4
<u>DESCRIPTION OF CAPITAL STOCK</u>	5
<u>DESCRIPTION OF WARRANTS</u>	7
<u>PLAN OF DISTRIBUTION</u>	9
<u>LEGAL MATTERS</u>	12
<u>EXPERTS</u>	12
<u>WHERE YOU CAN FIND MORE INFORMATION</u>	12
<u>INCORPORATION OF DOCUMENTS BY REFERENCE</u>	13

ABOUT THIS PROSPECTUS

This prospectus is part of a registration statement that we filed with the U.S. Securities and Exchange Commission or SEC using a “shelf” registration process. Under the shelf registration process, we may sell any combination of the securities described in this prospectus in one or more offerings, up to a maximum aggregate initial offering price of \$75,000,000.

This prospectus only provides you with a general description of the securities we may offer. Each time we sell securities described in the prospectus we will provide a supplement to this prospectus that will contain specific information about the terms of that offering, including the specific amounts, prices and terms of the securities offered. The prospectus supplement may also add, update or change information contained in this prospectus. To the extent there is a conflict between the information contained in this prospectus and the accompanying prospectus supplement, you should rely on the information in the accompanying prospectus supplement, provided that if any statement in one of these documents is inconsistent with a statement in another document having a later date—for example, a document incorporated by reference in this prospectus or any accompanying prospectus supplement—the statement in the later-dated document modifies or supersedes the earlier statement. You should carefully read both this prospectus and any accompanying prospectus supplement or other offering materials, together with the additional information described under the heading “Where You Can Find More Information.”

You should rely only on the information contained or incorporated by reference in this prospectus, accompanying prospectus supplements and any related free writing prospectus. We have not authorized anyone to provide you with different information. No dealer, salesperson or other person is authorized to give any information or to represent anything not contained in this prospectus, any accompanying prospectus supplement or any related free writing prospectus.

This prospectus and any accompanying prospectus supplement, free writing prospectus or other offering materials do not contain all of the information included in the registration statement as permitted by the rules and regulations of the SEC. For further information, we refer you to the registration statement on Form S-3, of which this prospectus is a part, including its exhibits. We are subject to the informational requirements of the Securities Exchange Act of 1934, as amended, and, therefore, file reports and other information with the SEC. Statements contained in this prospectus and any accompanying prospectus supplement, free writing prospectus or other offering materials about the provisions or contents of any agreement or other document are only summaries. If SEC rules require that any agreement or document be filed as an exhibit to the registration statement, you should refer to that agreement or document for its complete contents.

Neither the delivery of this prospectus nor any sale made under it implies that there has been no change in our affairs or that the information in this prospectus is correct as of any date after the date of this prospectus. You should assume that the information in this prospectus, information incorporated by reference any applicable prospectus supplement or any related free writing prospectus is accurate only as of the date on the front of the document and that any information we have incorporated by reference is accurate only as of the date of the document incorporated by reference, regardless of the time of delivery of this prospectus, any accompanying prospectus supplement or any related free writing prospectus, or any sale of a security.

In this prospectus, unless otherwise specified or the context requires otherwise, we use the terms “Ideal Power,” the “Company,” “we,” “us” and “our” to refer to Ideal Power Inc.

OUR BUSINESS

Overview

We are located in Austin, Texas. We develop and commercialize our Power Packet Switching Architecture, or PPSA technology, which is designed to improve the performance, size, weight, reliability, flexibility and manufacturing cost of electronic power converters. The electronic power converter vertical markets include power converters for residential, commercial, and utility-scale renewable energy systems, distributed wind generation, electric vehicle DC charging, variable speed motor drives and on-board power converters for electric vehicles. We believe that, due to the design advantages of our PPSA technology noted above, our technology can provide solutions that are both efficient and economically advantageous to these markets.

Our current focus is to provide solutions for high growth markets in battery energy storage systems or BESS, BESS with integrated photovoltaic or PV, and microgrid applications. We have specifically targeted commercial energy storage, which we feel will have higher economic value (in \$/kW or \$/kWh) than other vertical markets for energy storage due to peak demand cost savings and therefore will grow more rapidly. With our latest products, we are also targeting microgrid solutions for grid resiliency and off-grid power. Assuming we are successful in commercializing our technology in these initial vertical markets, we then plan to offer solutions to additional emerging and more mature vertical markets.

Currently, our products are manufactured by contract manufacturers and then sold by Ideal Power. For certain geographic markets and applications that would be challenging for us, as a small U.S. company, to serve, we may enter into licensing agreements with leading global electronics companies. These agreements would allow regional manufacturers to build our products under license for local markets, or we may license product designs to global brands for specific applications.

To date, our operations have been funded primarily through the sale of our common stock and convertible debt, as well as through U.S. Department of Energy grants. Our total revenue generated from inception to date as of September 30, 2014 is \$5,572,752 with almost half of that revenue coming from government grants. We have applied these revenues to research and product development, thereby reducing our capital requirements. We will continue to pursue research and development grants, where available, for the purpose of developing new products and improving our current products. We can make no assurances that additional grants will be available in the future.

We have incurred losses from operations for the years ended December 31, 2013 and 2012 and the nine months ended September 30, 2014. Our net loss was \$9.6 million and \$4.6 million, respectively, for the years ended December 31, 2013 and 2012 and \$4.9 million for the nine months ended September 30, 2014. Our accumulated deficit was \$16.8 million at December 31, 2013 and \$21.7 million at September 30, 2014.

Corporate Information

We were incorporated in Texas on May 17, 2007. We converted to a Delaware corporation on July 15, 2013. The address of our corporate headquarters is 4120 Freidrich Lane, Suite 100, Austin, Texas 78744 and our telephone number is (512) 264-1542. Our website can be accessed at www.idealpower.com. The information contained on, or that may be obtained from, our website is not, and shall not be deemed to be, a part of this prospectus.

RISK FACTORS

Investing in our securities involves significant risks. You should review carefully the risks and uncertainties described under the heading “Risk Factors” contained in, or incorporated into, the applicable prospectus supplement and any related free writing prospectus, and under similar headings in the other documents that are incorporated by reference herein or therein. Each of the referenced risks and uncertainties could adversely affect our business, operating results and financial condition, as well as adversely affect the value of an investment in our securities.

DISCLOSURE REGARDING FORWARD-LOOKING STATEMENTS

This prospectus contains forward-looking statements. Such forward-looking statements include those that express plans, anticipation, intent, contingency, goals, targets or future development and/or otherwise are not statements of historical fact. These forward-looking statements are based on our current expectations and projections about future events and they are subject to risks and uncertainties known and unknown that could cause actual results and developments to differ materially from those expressed or implied in such statements.

In some cases, you can identify forward-looking statements by terminology, such as “expects,” “anticipates,” “intends,” “estimates,” “plans,” “believes,” “seeks,” “may,” “should”, “could” or the negative of such terms or other similar expressions. Accordingly, these statements involve estimates, assumptions and uncertainties that could cause actual results to differ materially from those expressed in them. Any forward-looking statements are qualified in their entirety by reference to the factors discussed throughout this prospectus.

Forward-looking statements involve certain risks and uncertainties, many of which are beyond our control. If any of those risks and uncertainties materialize, actual results could differ materially from those discussed in any such forward-looking statement. Among the factors that could cause actual results to differ materially from those discussed in forward-looking statements are those discussed under the heading “Risk Factors” above, those discussed under the heading “Risk Factors” and in other sections of our Annual Report on Form 10-K for the year ended December 31, 2013, as well as in our other reports filed from time to time with the Securities Exchange Commission or SEC that are incorporated by reference into this prospectus. See “Where You Can Find More Information” and “Incorporation of Documents by Reference” for information about how to obtain copies of those documents.

All forward-looking statements in this prospectus and the documents incorporated by reference into it are made only as of the date of the document in which they are contained, based on information available to us as of the date of that document, and we caution you not to place undue reliance on forward-looking statements in light of the risks and uncertainties associated with them. Except as required by law, we undertake no obligation to update any forward-looking statements, whether as a result of new information, future events or otherwise.

USE OF PROCEEDS

Except as otherwise provided in the applicable prospectus supplement, information incorporated by reference or related free writing prospectus, we intend to use the net proceeds from the sale of the securities offered by us in this prospectus for general corporate purposes, which may include working capital, research and development expenditures, sales and marketing expenses, general corporate expenses, intellectual property acquisition costs and expenses and capital expenditures.

THE SECURITIES WE MAY OFFER

We may issue from time to time, in one or more offerings the following securities:

- shares of common stock;
- shares of preferred stock;
- warrants to purchase shares of preferred stock or common stock; or
- any combination of common stock, preferred stock, or warrants.

When we use the term “securities” in this prospectus, we mean any of the securities we may offer with this prospectus, unless we say otherwise. This prospectus, including the following summary, describes the general terms that may apply to the securities; the specific terms of any particular securities that we may offer will be described in a separate supplement to this prospectus, information incorporated by reference or related free writing prospectus, which may be in addition to or different from the general terms summarized in this prospectus.

The summaries contained in this prospectus and in any prospectus supplements, information incorporated by reference or related free writing prospectus may not contain all of the information that you would find useful. Accordingly, you should read the actual documents relating to any securities sold pursuant to this prospectus. See “Where You Can Find More Information” and “Incorporation of Documents by Reference” for information about how to obtain copies of those documents.

The terms of any particular offering, the initial offering price and the net proceeds to us will be contained in the prospectus supplement, information incorporated by reference or free writing prospectus, relating to each offering. Where applicable, a prospectus supplement, information incorporated by reference or related free writing prospectus will also describe any material United States federal income tax consequences relating to the securities offered and indicate whether the securities offered are or will be listed on any securities exchange.

DESCRIPTION OF CAPITAL STOCK

The following is a brief description of our capital stock. This summary does not purport to be complete in all respects. This description is subject to and qualified entirely by the terms of our Certificate of Incorporation, our bylaws, and certain provisions of applicable law. See “Where You Can Find More Information” and “Incorporation of Documents by Reference”.

Authorized Capitalization

We have 60,000,000 shares of authorized capital stock, consisting of 50,000,000 shares of authorized common stock and 10,000,000 shares of authorized preferred stock, all with a par value of \$0.001 per share. As of November 24, 2014, we had 7,048,235 shares of common stock outstanding and no shares of preferred stock outstanding. Our authorized but unissued shares of common stock and preferred stock are available for issuance without further action by our stockholders, unless such action is required by applicable law or the rules of any stock exchange or automated quotation system on which our securities may be listed or traded.

Common Stock

Holders of our common stock are entitled to such dividends as may be declared by our board of directors out of funds legally available for such purpose, subject to any preferential dividend rights of any then outstanding preferred stock. The shares of common stock are neither redeemable nor convertible. Holders of common stock have no preemptive or subscription rights to purchase any of our securities.

Each holder of our common stock is entitled to one vote for each such share outstanding in the holder’s name. No holder of common stock is entitled to cumulate votes in voting for directors.

In the event of our liquidation, dissolution or winding up, the holders of our common stock are entitled to receive pro rata our assets, which are legally available for distribution, after payments of all debts and other liabilities and subject to the prior rights of any holders of preferred stock then outstanding. All of the outstanding shares of our common stock are fully paid and non-assessable. The shares of common stock offered by this prospectus will also be fully paid and non-assessable.

Our common stock is listed on The Nasdaq Capital Market under the symbol “IPWR”. We have not applied to list our common stock on any other exchange or quotation system.

Preferred Stock

Our Certificate of Incorporation permits us to issue up to 10,000,000 shares of preferred stock in one or more series and with rights and preferences that may be fixed or designated by our board of directors without any further action by our stockholders, subject to any limitations prescribed under Delaware law. We currently have no shares of preferred stock outstanding. If preferred stock is issued in the future, a prospectus supplement, information incorporated by reference or related free writing prospectus, as applicable, will explain the particular terms of the preferred stock and the extent to which these general provisions may apply. The specific terms of the preferred stock as described in a prospectus supplement information, incorporated by reference or related free writing prospectus will supplement and, if applicable, may modify or replace the general terms described in this section. This summary and any description of preferred stock in the applicable prospectus supplement, information incorporated by reference or related free writing prospectus is subject to and is qualified in its entirety by reference to all the provisions of any amended and restated certificate of incorporation, which we will file with the SEC for incorporation by reference into this prospectus. See “Where You Can Find More Information” and “Incorporation of Documents by Reference” for information on how to obtain a copy of our amended and restated certificate of incorporation when it is filed.

The issuance of preferred stock with certain voting, conversion and/or redemption rights may adversely affect the rights of holders of our common stock, including with respect to voting, dividends and liquidation. Preferred stock may be issued quickly with terms calculated to delay, defer or prevent a change in control of our Company or to make removal of management more difficult. Additionally, the issuance of preferred stock may decrease the market price of our common stock.

Stock Options and Warrants

As of September 30, 2014, we have reserved the following shares of common stock for issuance pursuant to stock option and warrant agreements:

- 1,323,259 shares of our common stock are reserved for issuance under various outstanding option agreements, at a weighted average exercise price of \$6.378 per share;
- 1,617,376 shares of our common stock, at a weighted average exercise price of \$4.456 per share, are reserved for issuance under various outstanding warrant agreements; and
- 219,580 shares of our common stock have been reserved for the issuance of awards under our 2013 Equity Incentive Plan.

Anti-Takeover Effects of Certain Provisions of Delaware Law and Our Charter Documents

The following is a summary of certain provisions of Delaware law, our Certificate of Incorporation and our bylaws. This summary does not purport to be complete and is qualified in its entirety by reference to the corporate law of Delaware and our Certificate of Incorporation and bylaws.

Effect of Delaware Anti-Takeover Statute. We are subject to Section 203 of the Delaware General Corporation Law, an anti-takeover law. In general, Section 203 prohibits a Delaware corporation from engaging in any business combination (as defined below) with any interested stockholder (as defined below) for a period of three years following the date that the stockholder became an interested stockholder, unless:

- prior to that date, the board of directors of the corporation approved either the business combination or the transaction that resulted in the stockholder becoming an interested stockholder;
- upon consummation of the transaction that resulted in the stockholder becoming an interested stockholder, the interested stockholder owned at least 85% of the voting stock of the corporation outstanding at the time the transaction commenced, excluding for purposes of determining the number of shares of voting stock outstanding (but not the voting stock owned by the interested stockholder) those shares owned by persons who are directors and officers and by excluding employee stock plans in which employee participants do not have the right to determine whether shares held subject to the plan will be tendered in a tender or exchange offer; or
- on or subsequent to that date, the business combination is approved by the board of directors of the corporation and authorized at an annual or special meeting of stockholders, and not by written consent, by the affirmative vote of at least 66 2/3% of the outstanding voting stock that is not owned by the interested stockholder.

Section 203 defines “business combination” to include the following:

- any merger or consolidation involving the corporation and the interested stockholder;
- any sale, lease, exchange, mortgage, transfer, pledge or other disposition of 10% or more of the assets of the corporation involving the interested stockholder;
- subject to certain exceptions, any transaction that results in the issuance or transfer by the corporation of any stock of the corporation to the interested stockholder;
- subject to limited exceptions, any transaction involving the corporation that has the effect of increasing the proportionate share of the stock of any class or series of the corporation beneficially owned by the interested stockholder; or
- the receipt by the interested stockholder of the benefit of any loans, advances, guarantees, pledges or other financial benefits provided by or through the corporation.

In general, Section 203 defines an “interested stockholder” as any entity or person beneficially owning 15% or more of the outstanding voting stock of the corporation, or who beneficially owns 15% or more of the outstanding voting stock of the corporation at any time within a three-year period immediately prior to the date of determining whether such person is an interested stockholder, and any entity or person affiliated with or controlling or controlled by any of these entities or persons.

Our Charter Documents. Our charter documents include provisions that may have the effect of discouraging, delaying or preventing a change in control or an unsolicited acquisition proposal that a stockholder might consider favorable, including a proposal that might result in the payment of a premium over the market price for the shares held by our stockholders. Certain of these provisions are summarized in the following paragraphs.

Effects of authorized but unissued common stock and blank check preferred stock. One of the effects of the existence of authorized but unissued common stock and undesignated preferred stock may be to enable our board of directors to make more difficult or to discourage an attempt to obtain control of our Company by means of a merger, tender offer, proxy contest or otherwise, and thereby to protect the continuity of management. If, in the due exercise of its fiduciary obligations, the board of directors were to determine that a takeover proposal was not in our best interest, such shares could be issued by the board of directors without stockholder approval in one or more transactions that might prevent or render more difficult or costly the completion of the takeover transaction by diluting the voting or other rights of the proposed acquirer or insurgent stockholder group, by putting a substantial voting block in institutional or other hands that might undertake to support the position of the incumbent board of directors, by effecting an acquisition that might complicate or preclude the takeover, or otherwise.

In addition, our Certificate of Incorporation grants our board of directors broad power to establish the rights and preferences of authorized and unissued shares of preferred stock. The issuance of shares of preferred stock could decrease the amount of earnings and assets available for distribution to holders of shares of common stock. The issuance also may adversely affect the rights and powers, including voting rights, of those holders and may have the effect of delaying, deterring or preventing a change in control of our Company.

Cumulative Voting. Our Certificate of Incorporation does not provide for cumulative voting in the election of directors, which would allow holders of less than a majority of the stock to elect some directors.

No Stockholder Action by Written Consent. Our Certificate of Incorporation expressly prohibits stockholders from acting by written consent. This means that stockholders may only act at annual or special meetings.

Vacancies. Our Certificate of Incorporation provides that all vacancies may be filled by the affirmative vote of a majority of directors then in office, even if less than a quorum.

Special Meeting of Stockholders. A special meeting of stockholders may only be called by the Chairman of the board of directors, the Chief Executive Officer, or the board of directors at any time and for any purpose or purposes as shall be stated in the notice of the meeting, and shall be called by the Secretary upon the written request of the holders of record of at least 25% of the outstanding shares of common stock. This provision could prevent stockholders from calling a special meeting because, unless certain significant stockholders were to join with them, they might not obtain the percentage necessary to request the meeting. Therefore, stockholders holding less than 25% of the issued and outstanding common stock, without the assistance of management, may be unable to propose a vote on any transaction that would delay, defer or prevent a change of control, even if the transaction were in the best interests of our stockholders.

Requirements for Advance Notification of Stockholder Nominations and Proposals. Our Certificate of Incorporation and bylaws have advance notice procedures with respect to stockholder proposals and nominations of candidates for election as directors, other than nominations made by or at the direction of our board of directors or a committee of our board. The business to be conducted at a meeting will be limited to business properly brought before the meeting, in accordance with our Certificate of Incorporation and bylaws. Failure to follow the procedures set forth in our Certificate of Incorporation and bylaws will result in the chairman of the meeting disregarding the nomination or declaring that the proposed business will not be transacted.

Limitations on Directors' Liability

Our certificate of incorporation and bylaws contain provisions indemnifying our directors and officers to the fullest extent permitted by Delaware law.

In addition, as permitted by Delaware law, our certificate of incorporation provides that no director will be liable to us or our stockholders for monetary damages for breach of the director's fiduciary duty as a director. The effect of this provision is to restrict our rights and the rights of our stockholders in derivative suits to recover monetary damages against a director for breach of the director's fiduciary duty as a director, except that a director will be personally liable for:

- any breach of his or her duty of loyalty to us or our stockholders;
- acts or omissions not in good faith which involve intentional misconduct or a knowing violation of law;
- the payment of dividends or the redemption or purchase of stock in violation of Delaware law; or
- any transaction from which the director derived an improper personal benefit.

This provision does not affect a director's liability under the federal securities laws.

Disclosure of SEC Position on Indemnification for Securities Act Liabilities

Insofar as indemnification for liabilities arising under the Securities Act may be permitted for directors, officers and persons controlling us, we understand that it is the SEC's opinion that such indemnification is against public policy as expressed in the Securities Act and may therefore be unenforceable.

DESCRIPTION OF WARRANTS

We may issue warrants for the purchase of common stock and/or preferred stock in one or more series. We may issue warrants independently or together with common stock and/or preferred stock, and the warrants may be attached to or separate from these securities.

We will evidence each series of warrants by warrant certificates that we may issue under a separate agreement. We may enter into the warrant agreement with a warrant agent. Each warrant agent may be a bank that we select which has its principal office in the United States and a combined capital and surplus of at least \$50,000,000. We may also choose to act as our own warrant agent. We will indicate the name and address of any such warrant agent in the applicable prospectus supplement, information incorporated by reference or related free writing prospectus relating to a particular series of warrants.

We will describe in the applicable prospectus supplement, information incorporated by reference or related free writing prospectus, as applicable, the terms of the series of warrants, including, but not limited to:

- the offering price and aggregate number of warrants offered;
- the currency for which the warrants may be purchased;
- if applicable, the designation and terms of the securities with which the warrants are issued and the number of warrants issued with each such security or each principal amount of such security;
- if applicable, the date on and after which the warrants and the related securities will be separately transferable;
- in the case of warrants to purchase common stock or preferred stock, the number of shares of common stock or preferred stock, as the case may be, purchasable upon the exercise of one warrant and the price at which these shares may be purchased upon such exercise;
- the warrant agreement under which the warrants will be issued;
- the effect of any merger, consolidation, sale or other disposition of our business on the warrant agreement and the warrants;
- anti-dilution provisions of the warrants, if any;
- the terms of any rights to redeem or call the warrants;
- any provisions for changes to or adjustments in the exercise price or number of securities issuable upon exercise of the warrants;
- the dates on which the right to exercise the warrants will commence and expire or, if the warrants are not continuously exercisable during that period, the specific date or dates on which the warrants will be exercisable;
- the manner in which the warrant agreement and warrants may be modified;
- the identities of the warrant agent and any calculation or other agent for the warrants;
- federal income tax consequences of holding or exercising the warrants;
- the terms of the securities issuable upon exercise of the warrants;
- any securities exchange or quotation system on which the warrants or any securities deliverable upon exercise of the warrants may be listed; and
- any other specific terms, preferences, rights or limitations of or restrictions on the warrants.

Before exercising their warrants, holders of warrants will not have any of the rights of holders of the securities purchasable upon such exercise, including in the case of warrants to purchase common stock or preferred stock, the right to receive dividends, if any, or, payments upon our liquidation, dissolution or winding up or to exercise voting rights, if any.

This summary and any description of warrants in the applicable prospectus supplement, information incorporated by reference or related free writing prospectus is subject to and is qualified in its entirety by reference to all the provisions of any specific warrant document or agreement, which we will file with the SEC for incorporation by reference into this prospectus. See “Where You Can Find More Information” and “Incorporation of Documents by Reference” for information on how to obtain a copy of a warrant document when it is filed.

Exercise of Warrants

Each warrant will entitle the holder to purchase the securities that we specify in the applicable prospectus supplement, information incorporated by reference or related free writing prospectus at the exercise price that we describe in the applicable prospectus supplement, information incorporated by reference or related free writing prospectus. Unless we otherwise specify in the applicable prospectus supplement, information incorporated by reference or related free writing prospectus, holders of the warrants may exercise the warrants at any time up to 5:00 p.m. Eastern Time on the expiration date that we set forth in the applicable prospectus supplement, information incorporated by reference or related free writing prospectus. After the close of business on the expiration date, unexercised warrants will become void.

Holders of the warrants may exercise the warrants by delivering the warrant certificate representing the warrants to be exercised together with specified information, and paying the required amount to the warrant agent in immediately available funds, as provided in the applicable prospectus supplement, information incorporated by reference or related free writing prospectus. We will set forth on the reverse side of the warrant certificate, and in the applicable prospectus supplement, information incorporated by reference or related free writing prospectus, the information that the holder of the warrant will be required to deliver to the warrant agent.

Until the warrant is properly exercised, no holder of any warrant will be entitled to any rights of a holder of the securities purchasable upon exercise of the warrant.

Upon receipt of the required payment and the warrant certificate properly completed and duly executed at the corporate trust office of the warrant agent or any other office indicated in the applicable prospectus supplement, information incorporated by reference or related free writing prospectus, we will issue and deliver the securities purchasable upon such exercise. If fewer than all of the warrants represented by the warrant certificate are exercised, then we will issue a new warrant certificate for the remaining amount of warrants. If we so indicate in the applicable prospectus supplement, information incorporated by reference or related free writing prospectus, holders of the warrants may surrender securities as all or part of the exercise price for warrants.

Enforceability of Rights By Holders of Warrants

Any warrant agent will act solely as our agent under the applicable warrant agreement and will not assume any obligation or relationship of agency or trust with any holder of any warrant. A single bank or trust company may act as warrant agent for more than one issue of warrants. A warrant agent will have no duty or responsibility in case of any default by us under the applicable warrant agreement or warrant, including any duty or responsibility to initiate any proceedings at law or otherwise, or to make any demand upon us. Any holder of a warrant may, without the consent of the related warrant agent or the holder of any other warrant, enforce by appropriate legal action its right to exercise, and receive the securities purchasable upon exercise of, its warrants in accordance with their terms.

Warrant Agreement Will Not Be Qualified Under Trust Indenture Act

No warrant agreement will be qualified as an indenture, and no warrant agent will be required to qualify as a trustee, under the Trust Indenture Act. Therefore, holders of warrants issued under a warrant agreement will not have the protection of the Trust Indenture Act with respect to their warrants.

Calculation Agent

Calculations relating to warrants may be made by a calculation agent, an institution that we may appoint as our agent for this purpose. The prospectus supplement for a particular warrant will name the institution that we have appointed, if applicable, to act as the calculation agent for that warrant as of the original issue date for that warrant. We may appoint a different institution to serve as calculation agent from time to time after the original issue date without the consent or notification of the holders.

The calculation agent's determination of any amount of money payable or securities deliverable with respect to a warrant will be final and binding in the absence of manifest error.

PLAN OF DISTRIBUTION

We may sell the securities offered by this prospectus from time to time in one or more transactions, including without limitation:

- directly to one or more purchasers;
- through agents;
- to or through underwriters, brokers or dealers;
- through a rights offering; or
- through a combination of any of these methods.

A distribution of the securities offered by this prospectus may also be effected through the issuance of derivative securities, including without limitation, warrants, subscriptions, exchangeable securities, forward delivery contracts and the writing of options.

In addition, the manner in which we may sell some or all of the securities covered by this prospectus, include, without limitation, through:

- a block trade in which a broker-dealer will attempt to sell as agent, but may position or resell a portion of the block, as principal, in order to facilitate the transaction;
- purchases by a broker-dealer, as principal, and resale by the broker-dealer for its account;
- ordinary brokerage transactions and transactions in which a broker solicits purchasers;
- sales “at the market” to or through a market maker or into an existing trading market, on an exchange or otherwise; and
- sales in other ways not involving market makers or established trading markets, including direct sales to purchasers.

We may also enter into hedging transactions. For example, we may:

- enter into transactions with a broker-dealer or affiliate thereof in connection with which such broker-dealer or affiliate will engage in short sales of the common shares pursuant to this prospectus, in which case such broker-dealer or affiliate may use common shares received from us, as applicable, to close out its short positions;
- enter into option or other types of transactions that require us to deliver common shares to a broker-dealer or an affiliate thereof, who will then resell or transfer the common shares under this prospectus; or
- loan or pledge the common shares to a broker-dealer or an affiliate thereof, who may sell the loaned shares or, in an event of default in the case of a pledge, sell the pledged shares pursuant to this prospectus.

In addition, we may enter into derivative or hedging transactions with third parties, or sell securities not covered by this prospectus to third parties in privately negotiated transactions. In connection with such a transaction, the third parties may sell securities covered by and pursuant to this prospectus and an applicable prospectus supplement, information incorporated by reference, related free writing prospectus, or pricing supplement, as the case may be. If so, the third party may use securities borrowed from us or others to settle such sales and may use securities received from us to close out any related short positions. We may also loan or pledge securities covered by this prospectus and an applicable prospectus supplement, information incorporated by reference or related free writing prospectus to third parties, who may sell the loaned securities or, in an event of default in the case of a pledge, sell the pledged securities pursuant to this prospectus and the applicable prospectus supplement, information incorporated by reference, related free writing prospectus, or pricing supplement, as the case may be.

We will describe the terms of the offering of the securities in a prospectus supplement, information incorporated by reference or related free writing prospectus, including:

- the name or names of any underwriters or agents and the amounts of securities underwritten or purchased by each of them, if any;
- the public offering price or purchase price of the securities and the net proceeds to be received by us from the sale;
- any delayed delivery arrangements;
- any underwriting discounts or agency fees and other items constituting underwriters’ or agents’ compensation;
- any discounts or concessions allowed or reallocated or paid to dealers; and
- any securities exchange or markets on which the securities may be listed.

The offer and sale of the securities described in this prospectus by us, the underwriters or the third parties described above may be effected from time to time in one or more transactions, including privately negotiated transactions, either:

- at a fixed price or prices, which may be changed;
- at market prices prevailing at the time of sale;
- at prices related to the prevailing market prices; or
- at negotiated prices.

To the extent required, this prospectus may be amended or supplemented from time to time to describe a specific plan of distribution.

General

Any public offering price and any discounts, commissions, concessions or other items constituting compensation allowed or reallocated or paid to underwriters, dealers, agents or remarketing firms may be changed from time to time. Underwriters, dealers, agents and remarketing firms that participate in the distribution of the offered securities may be “underwriters” as defined in the Securities Act. Any discounts or commissions they receive from us and any profits they receive on the resale of the offered securities may be treated as underwriting discounts and commissions under the Securities Act. We will identify any underwriters, agents or dealers and describe their commissions, fees or discounts in the applicable prospectus supplement, information incorporated by reference, related free writing prospectus or pricing supplement, as the case may be.

Underwriters and Agents

If underwriters are used in a sale, they will acquire the offered securities for their own account. The underwriters may resell the offered securities in one or more transactions, including negotiated transactions. These sales may be made at a fixed public offering price or prices, which may be changed, at market prices prevailing at the time of the sale, at prices related to such prevailing market price or at negotiated prices. We may offer the securities to the public through an underwriting syndicate or through a single underwriter. The underwriters in any particular offering will be mentioned in the applicable prospectus supplement, information incorporated by reference, related free writing prospectus or pricing supplement, as the case may be.

Unless otherwise specified in connection with any particular offering of securities, the obligations of the underwriters to purchase the offered securities will be subject to certain conditions contained in an underwriting agreement that we will enter into with the underwriters at the time of the sale to them. The underwriters will be obligated to purchase all of the securities of the series offered if any of the securities are purchased, unless otherwise specified in connection with any particular offering of securities. Any initial offering price and any discounts or concessions allowed, reallocated or paid to dealers may be changed from time to time.

We may designate agents to sell the offered securities. Unless otherwise specified in connection with any particular offering of securities, the agents will agree to use their best efforts to solicit purchases for the period of their appointment. We may also sell the offered securities to one or more remarketing firms, acting as principals for their own accounts or as agents for us. These firms will remarket the offered securities upon purchasing them in accordance with a redemption or repayment pursuant to the terms of the offered securities. A prospectus supplement or pricing supplement, as the case may be will identify any remarketing firm and will describe the terms of its agreement, if any, with us and its compensation.

In connection with offerings made through underwriters or agents, we may enter into agreements with such underwriters or agents pursuant to which they will receive our outstanding securities in consideration for the securities being offered to the public for cash. In connection with these arrangements, the underwriters or agents may also sell securities covered by this prospectus to hedge their positions in these outstanding securities, including in short sale transactions. If so, the underwriters or agents may use the securities received from us under these arrangements to close out any related open borrowings of securities.

Dealers

We may sell the offered securities to dealers as principals. We may negotiate and pay dealers’ commissions, discounts or concessions for their services. The dealer may then resell such securities to the public either at varying prices to be determined by the dealer or at a fixed offering price agreed to with us at the time of resale. Dealers engaged by us may allow other dealers to participate in resales.

Direct Sales

We may choose to sell the offered securities directly. In this case, no underwriters or agents would be involved.

Institutional Purchasers

We may authorize agents, dealers or underwriters to solicit certain institutional investors to purchase offered securities on a delayed delivery basis pursuant to delayed delivery contracts providing for payment and delivery on a specified future date. The applicable prospectus supplement, information incorporated by reference, related free writing prospectus or pricing supplement, as the case may be, will provide the details of any such arrangement, including the offering price and commissions payable on the solicitations.

We will enter into such delayed contracts only with institutional purchasers that we approve. These institutions may include commercial and savings banks, insurance companies, pension funds, investment companies and educational and charitable institutions.

Indemnification; Other Relationships

We may have agreements with agents, underwriters, dealers and remarketing firms to indemnify them against certain civil liabilities, including liabilities under the Securities Act. Agents, underwriters, dealers and remarketing firms, and their affiliates, may engage in transactions with, or perform services for, us in the ordinary course of business. This includes commercial banking and investment banking transactions.

Market-Making, Stabilization and Other Transactions

There is currently no market for any of the offered securities, other than our common stock which is listed on The NASDAQ Capital Market. If the offered securities are traded after their initial issuance, they may trade at a discount from their initial offering price, depending upon prevailing interest rates, the market for similar securities and other factors. While it is possible that an underwriter could inform us that it intends to make a market in the offered securities, such underwriter would not be obligated to do so, and any such market-making could be discontinued at any time without notice. Therefore, no assurance can be given as to whether an active trading market will develop for the offered securities. We have no current plans for listing of the preferred stock or warrants on any securities exchange or quotation system; any such listing with respect to any particular preferred stock or warrants will be described in the applicable prospectus supplement, information incorporated by reference, related free writing prospectus or pricing supplement, as the case may be.

In connection with any offering of common stock, the underwriters may purchase and sell common stock in the open market. These transactions may include short sales, syndicate covering transactions and stabilizing transactions. Short sales involve syndicate sales of common stock in excess of the number of shares to be purchased by the underwriters in the offering, which creates a short position. "Covered" short sales are sales of shares made in an amount up to the number of shares represented by the underwriters' over-allotment option. In determining the source of shares to close out the covered syndicate short position, the underwriters will consider, among other things, the price of shares available for purchase in the open market as compared to the price at which they may purchase shares through the over-allotment option. Transactions to close out the covered syndicate short involve either purchases of the common stock in the open market after the distribution has been completed or the exercise of the over-allotment option. The underwriters may also make "naked" short sales of shares in excess of the over-allotment option. The underwriters must close out any naked short position by purchasing common stock in the open market. A naked short position is more likely to be created if the underwriters are concerned that there may be downward pressure on the price of the shares in the open market after pricing that could adversely affect investors who purchase in the offering. Stabilizing transactions consist of bids for or purchases of shares in the open market while the offering is in progress for the purpose of pegging, fixing or maintaining the price of the securities.

In connection with any offering, the underwriters may also engage in penalty bids. Penalty bids permit the underwriters to reclaim a selling concession from a syndicate member when the securities originally sold by the syndicate member are purchased in a syndicate covering transaction to cover syndicate short positions. Stabilizing transactions, syndicate covering transactions and penalty bids may cause the price of the securities to be higher than it would be in the absence of the transactions. The underwriters may, if they commence these transactions, discontinue them at any time.

LEGAL MATTERS

The validity of the issuance of the securities offered hereby will be passed upon for us by DLA Piper LLP (US), Austin, Texas.

EXPERTS

The audited financial statements as of December 31, 2013 and 2012 and for the years then ended incorporated by reference in this prospectus and elsewhere in the registration statement have been so incorporated by reference in reliance upon the report of Gumbiner Savett Inc., an independent registered public accounting firm, upon the authority of said firm as experts in accounting and auditing in giving said report.

WHERE YOU CAN FIND MORE INFORMATION

This prospectus constitutes a part of a registration statement on Form S-3 filed under the Securities Act. As permitted by the SEC's rules, this prospectus and any prospectus supplement, which form a part of the registration statement, do not contain all the information that is included in the registration statement. You will find additional information about us in the registration statement. Any statements made in this prospectus or any prospectus supplement concerning legal documents are not necessarily complete and you should read the documents that are filed as exhibits to the registration statement or otherwise filed with the SEC for a more complete understanding of the document or matter.

We file annual, quarterly and current reports, proxy statements and other information with the SEC. You may read, without charge, and copy the documents we file at the SEC's public reference rooms in Washington, D.C. at 100 F Street, NE, Room 1580, Washington, DC 20549. You can request copies of these documents by writing to the SEC and paying a fee for the copying cost. Please call the SEC at 1-800-SEC-0330 for further information on the public reference rooms. Our SEC filings are also available to the public at no cost from the SEC's website at <http://www.sec.gov>.

INCORPORATION OF DOCUMENTS BY REFERENCE

The SEC allows us to “incorporate by reference” the information we file with the SEC, which means that we can disclose important information to you by referring you to those documents filed separately with the SEC. The information incorporated by reference herein is considered part of this prospectus. Any statement contained in a document which is incorporated by reference in this prospectus is automatically updated and superseded if information contained in this prospectus, or information that we later file with the SEC prior to the termination of this offering, modifies or replaces this information. The following documents filed with the SEC are incorporated by reference in this prospectus, except for any document or portion thereof deemed to be “furnished” and not filed in accordance with SEC rules:

- our Annual Report on Form 10-K for the fiscal year ended December 31, 2013;
- our Quarterly Report on Form 10-Q for the quarterly period ended March 31, 2014;
- our Quarterly Report on Form 10-Q for the quarterly period ended June 30, 2014;
- our Quarterly Report on Form 10-Q for the quarterly period ended September 30, 2014;
- our Current Report on Form 8-K filed on January 8, 2014;
- our Current Report on Form 8-K filed on March 6, 2014;
- our Current Report on Form 8-K filed on May 13, 2014;
- our Current Report on Form 8-K filed on May 29, 2014;
- our Current Report on Form 8-K filed on August 13, 2014;
- our Current Report on Form 8-K filed on September 19, 2014;
- our Current Report on Form 8-K filed on November 12, 2014;
- our Definitive Proxy Statement on Schedule 14A filed on April 21 2014;
- the description of our common stock set forth in the prospectus filed pursuant to Rule 424(b)(3) on November 27, 2013, including any amendments or reports filed for the purpose of updating such description, as supplemented by the “Description of Capital Stock” found on page 7 of this prospectus; and
- all documents filed by Ideal Power Inc. under Sections 13(a), 13(c), 14 or 15(d) of the Exchange Act, after the filing date of this initial registration statement and prior to the date of effectiveness of this registration statement, and on or after the date of this prospectus and before the termination of this offering shall be deemed to be incorporated by reference into this prospectus from the respective dates of filing of such documents.

As explained above in “Where You Can Find More Information,” these incorporated documents (as well as other documents filed by us under the Exchange Act) are available at the SEC and may be accessed in a number of ways, including online via the Internet.

We will provide without charge to each person, including any beneficial owner, to whom this prospectus is delivered, upon his or her written or oral request, a copy of any or all documents referred to above which have been or may be incorporated by reference into this prospectus excluding exhibits to those documents unless they are specifically incorporated by reference into those documents. Written or telephone requests should be directed to:

Ideal Power Inc.
4120 Freidrich Lane, Suite 100
Austin, TX 78744
Attn.: Chief Executive Officer
Tel: (512) 264-1542

We also maintain a web site at www.idealpower.com. The information on our website is not considered a part of, or incorporated by reference in, this prospectus or any other document we file with or furnish to the SEC.

1,935,500 Shares of



Common Stock

PROSPECTUS SUPPLEMENT

Sole Book-Running Manager

Roth Capital Partners

Co-Managers

National Securities Corporation

Northland Capital Markets

May 18, 2015